

# ULINE H-3579 CLARKE FLOOR CLEANING MACHINE

1-800-295-5510  
uline.com

## PRIMARY ASSEMBLY

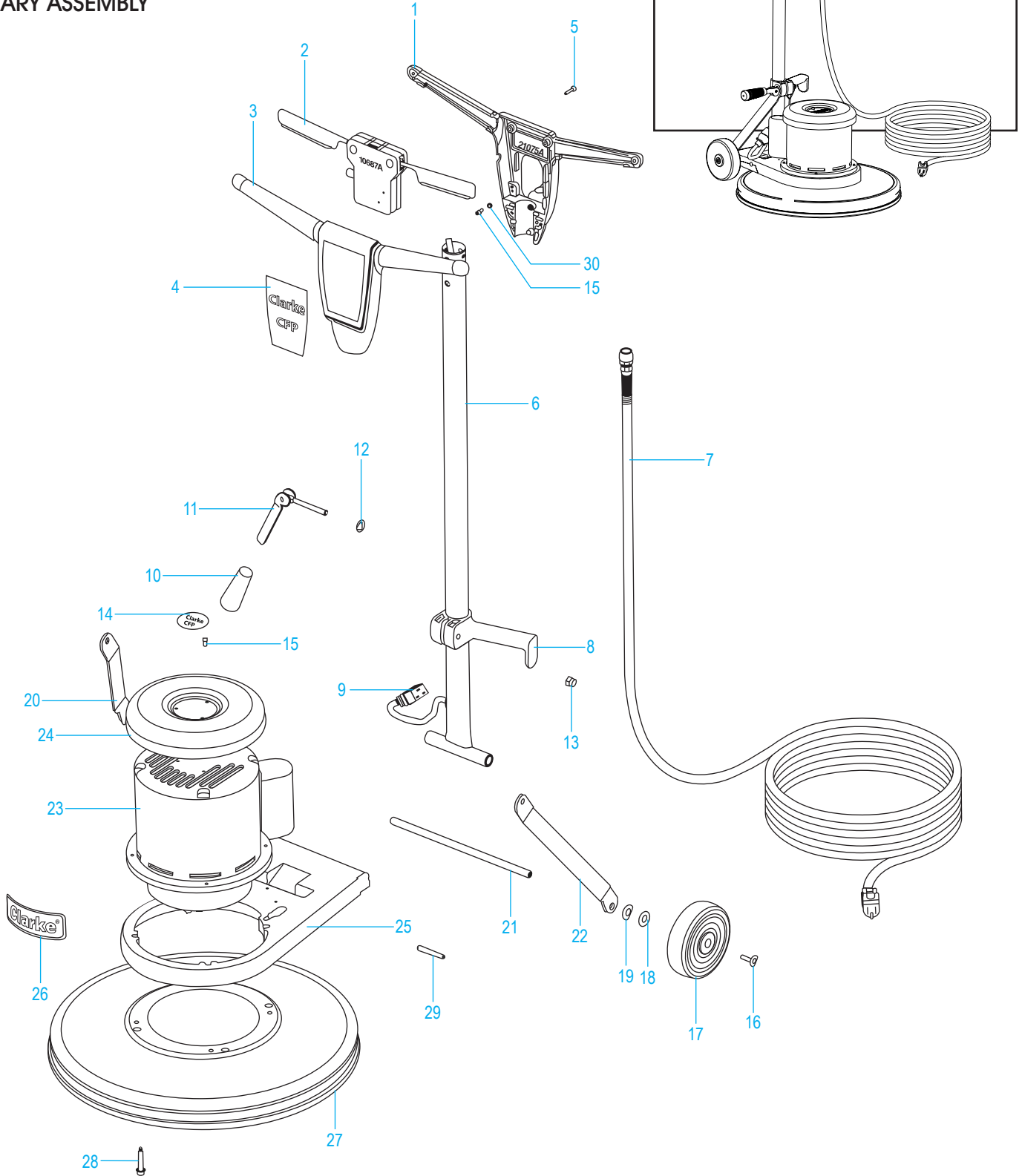

#	DESCRIPTION	QTY.	ULINE PART NO.	MFG. PART NO.
1	Handle, Back	1	-----	21075A
2	Module, Interlock	1	-----	10687A
3	Handle, Front	1	-----	21074A
4	Label, Handle	1	-----	71020A
5	Screw, 10-32 x 3/4"	6	-----	80284A
6	Tube, Handle	1	-----	61373A
7	Cord, 14/3 x 50'	1	-----	40788A
	Cord, Strain Relief (Not Shown)	1	-----	467504
	Cord, Terminal FIFQD (Not Shown)	2	-----	47711A
8	Clamp, Handle	1	-----	50781A
9	Cord, Interconnect	1	-----	40789A
10	Grip, Handle	1	-----	56057675
11	Cam, Assembly	1	-----	441401
	Cam Lock Bolt (Not Shown)	1	-----	441301
	Cam, Locking (Not Shown)	1	-----	461404
	Pin, Coiled (Not Shown)	1	-----	53662A
12	Washer, Wear	1	-----	980349
13	Nut, 3/8" - 16 ESNA	1	-----	920342
14	Label (CFP-1700)	1	-----	71023A
14	Label (CFP-2000)	1	-----	71027A
15	Screw, 10-32 x 3/8"	5	-----	80290A
16	Screw, 1/4-20 x 1"	2	-----	80292A
17	Wheel	2	-----	56201018
18	Washer, 17/32 x 1-1/16" Plain	2	-----	980648
19	Washer, Bowd	2	-----	80295A
20	Link Arm - Right	1	-----	61741A
21	Axle	1	-----	61725A
22	Link Arm - Left	1	-----	61740A
23A	Motor (See Page 3)	1	H-3581	40763A
23B	Gearbox (See Page 4)	1	-----	53646A
24	Drip Cover	1	-----	61716A
25	Mainframe	1	-----	21088A
26	Label, Motor Clarke	1	-----	73323A
27	Housing, Assembly (CFP-1700)	1	-----	11006A
	Housing (CFP-1700)	1	-----	61715A
	Bumper (CFP-1700)	1	-----	30381A
27	Housing, Assembly (CFP-2000)	1	-----	11007A
	Housing (CFP-2000)	1	-----	61714A
	Bumper (CFP-2000)	1	-----	50784A
28	Screw, 5/16" - 18	4	-----	80294A
29	Pin, Split 1/2"	2	-----	53833A
30	Washer, Flat #10	1	-----	80291A
	Pad Driver (CFP-1700) (Not Shown)	1	-----	30638A
	Pad Driver (CFP-2000) (Not Shown)	1	-----	30639A

**ULINE H-3579**  
**CLARKE FLOOR**  
**CLEANING MACHINE**

1-800-295-5510  
 uline.com

MOTOR ASSEMBLY

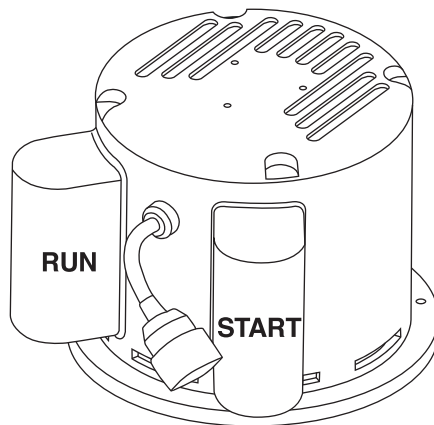

DESCRIPTION	QTY.	ULINE PART NO.	MFG. PART NO.
Rotor, 1.5HP, 60Hz	1	-----	53193A
Capacitor, Start	1	-----	40694A
Capacitor, Run	1	-----	53191A
Stator, 1.5HP, 60Hz	1	-----	53189A
Cover, Capacitor	2	-----	53360A
End Shield, Aluminum	1	-----	40698A
Cover, Wiring	1	-----	40699A
Switch, Start	1	-----	53190A
Centrifugal 4-Pole 60Hz	1	-----	53195A
Label, Connection	1	-----	70787A
Screw, 8-32 x 3/8"	11	-----	85303A
Bearing, Ball - 6203	1	-----	902550
Plate, Mounting	1	-----	53848A
Screw, 10-32 x 1"	6	-----	80141A
Wire Nut, Orange	2	-----	911177
Cord, IEC	1	-----	41053A
Strain Relief	1	-----	747553

# ULINE H-3579

## CLARKE FLOOR CLEANING MACHINE

1-800-295-5510  
uline.com

### GEARBOX ASSEMBLY

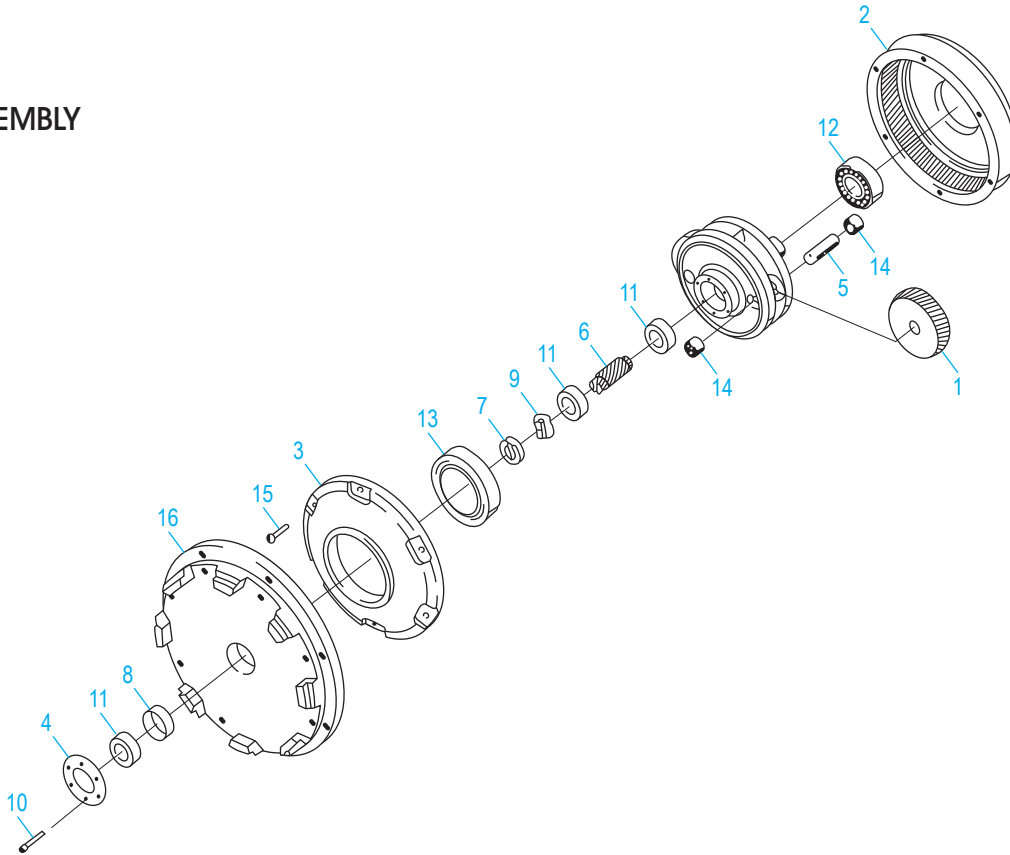

#	DESCRIPTION	QTY.	ULINE PART NO.	MFG. PART NO.
1	Gear, Planet	3	-----	54408A
2	Gear, Ring	1	-----	54856A
3	Cover, Gearbox	1	-----	54858A
4	Retainer, Bearing	1	-----	56922A
5	Shaft, Planet	3	-----	58312A
6	Gear, Pinion	1	-----	58313A
7	Retainer, Shaft	1	-----	58314A
8	Spacer, Sleeve	1	-----	58520A
9	Coupling, Shaft	1	-----	69195A
10	Screw, 10-32 x 1"	6	-----	80141A
11	Bearing, Ball - 6002	3	-----	902606
12	Bearing, Ball - 6204	1	-----	902654
13	Bearing, Ball - 6010	1	-----	902736
14	Bearing, Needle	6	-----	902737
15	Screw, 10-24 x 3/4"	6	-----	84808A
16	Plate, Mounting	1	-----	53848A
	Grease - 14 Ounce Tube (Not Shown)	1	-----	503802