

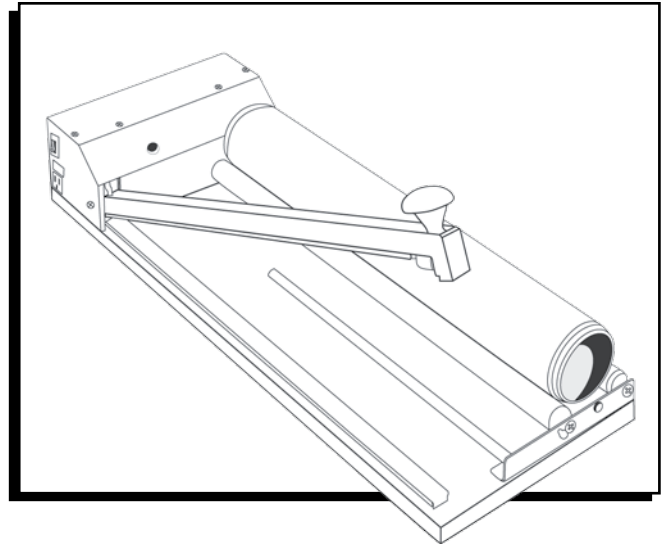

H-140, H-312
H-375, H-460

INDUSTRIAL SHRINK WRAP SYSTEM

1-800-295-5510
uline.com



SPECIFICATIONS

MODEL NUMBER	H-460	H-312	H-140	H-375
Applications	DVDs/Video Games; Computer Software; CDs/Tapes; Books/Magazines	Printing; Computer Software; Manuals; CDs/Tapes; Hardware	Printing; General Packaging; Damaged Package Recovery	Art/Frame; Gift Baskets; Posters; Retail Packaging
Length of Sealing Area	13"	18"	24"	40"
Maximum Film Width	13"	18"	24"	40"
Maximum Film Weight	100LBS	100LBS	100LBS	100LBS
Film Core Diameter	1-7/8" and 3"	1-7/8" and 3"	1-7/8" and 3"	1-7/8" and 3"
Power Supply (Primary)	110VAC*	110VAC*	110VAC*	110VAC*
Voltage (Secondary) (Deluxe)	14VAC	20VAC	30VAC	38VAC
Amperage	3 amps	5 amps	5 amps	8 amps
Cycles	50/60hz. 1 phase	50/60hz. 1 phase	50/60hz. 1 phase	50/60hz. 1 phase

HEAT GUN 110A/C – 60hz. – 1100 watts – Temperature range: 50° F. – 1100° F. Weight: 2LB.

* 220 VAC also available upon request.

SAFETY INSTRUCTIONS

Before using the Industrial Shrink Wrap System, carefully read all of the instructions. Pay close attention to safety guidelines and warnings included for your protection. **Save these instructions for future reference.**

WARNINGS FOR SHRINK WRAP SYSTEM (SEALER AND HEATGUN):

- Make sure the work area is clean and dry before using the sealer. This is an electrical appliance and can be a potential shock or fire hazard, especially if operated near refuse or in a wet environment.
- Only use system with standard 115 volt 15 amp wall receptacle. No other form of wiring is safe or advisable. Unplug the system after use for additional safety precaution.
- To reduce the risk of fire or electric shock, do not expose to rain or moisture. Store indoors.
- If the sealer or heatgun stops working during operation, fails to operate when turned on, or otherwise ceases to function properly, turn switch to the off position, disconnect from the power supply and call Uline for assistance at 1-800-295-5510.
- Never attempt any repairs on the sealer or heatgun. A qualified service technician must do all repairs. The parts supplied in your maintenance parts kit are for maintenance of the machine to keep it in good operating condition and may be an exception to this rule.
- Inspect power cords periodically and if damaged or defective, have repaired by a qualified service technician. Extension cords are not recommended, however if one is used it must be a U.L. listed three-wire extension cord with a three-prong grounding plug and a rated capacity of 1800 watts or greater (14 gauge or heavier for up to 25 ft. and 12 gauge if cord is longer). Inspect cord carefully before using and never use a cord that shows any sign of damage or defect.
- Never yank the cord from an electrical outlet or use it to tie down the arm or for any other purpose other than that for which it was intended.
- Guard against electric shock by preventing contact with grounded surfaces or other appliances.
- Keep children and visitors away from the work area, the sealer and its accessories.
- Keep work area well lighted.
- Never try to seal anything other than plastic films intended for use on this sealer.
- Never use the sealer after partial failure.
- Maintain proper footing and balance at all times.
- Do not wear loose-fitting clothing or jewelry. Wear non-skid footwear and a protective hair covering to contain long hair.
- Always wear eye protection and protective work gloves.
- When servicing, use only identical replacement parts.
- Never use the sealer or heatgun near anything that is or could be considered combustible or flammable materials or gases. Always check your work area carefully; materials or gases that may ignite may not be readily apparent and could result in property damage and personal injury.
- Never use the sealer or heatgun after recently pumping gasoline or using any other combustible gas or liquid; fumes or residue may still be on your skin or in your clothing.

WARNINGS SPECIFIC TO THE SEALER: (IN ADDITION TO SYSTEM WARNINGS)

- A live heating element is located on the underside of the arm under the Teflon tape. Use caution during operation. **DO NOT TOUCH THE ELEMENT.**
- Turn sealer off and disconnect (unplug) the sealer when not in use. Avoid unintentional starting. A sealer that is plugged in and left on could start and burn if the arm came down due to a broken spring or if something fell on the arm.
- If arm spring breaks, turn sealer off, disconnect from power supply immediately and call Uline for assistance at 1-800-295-5510.
- Only use AC outlet on side of machine with accessories intended for that purpose and rated to the capacity listed by the outlet. Specifically; an industrial heatgun.
- Only use fuse of capacity listed by the fuseholder.

SAFETY INSTRUCTIONS CONTINUED

SEALER CLEANING INSTRUCTIONS:

- Never use anything abrasive to clean the heating element. (i.e. steel wool, emery cloth or board, etc.) These can damage the wire and cause premature breakage.
- To clean the heating wire – first remove the pad from the channel under the arm. Then pull the arm down and allow the residue to burn off the arm. Wipe anything still clinging to the arm off with a piece of cardboard. After the wire has cooled and is visibly clean, cover with a new piece of 3-mil Teflon tape. NOTE: Teflon tape over the wire is only required when using PVC Shrinkfilm or Polyethylene to prevent build-up on wire and excessive smoking. When using Polyolefin type films, it is not required or suggested. The 10-mil Teflon tape on the scaling pad is always required for every application.
- To clean other exterior parts of the sealer, any non-flammable spray cleaner will suffice.
- Cleaning the sealer internally is not suggested or advised.
- If Teflon tape appears to be burnt, worn or damaged, replace with a new piece of tape.

WARNINGS SPECIFIC TO THE HEATGUN: (IN ADDITION TO SYSTEM WARNINGS)

- For the first few uses of a new heatgun there may be some smoking due to manufacturing oils being burnt off inside the gun. The smoke should disappear in less than a minute.
- The nozzle will turn dark over time due to high heat. This is normal and does not affect the performance or shorten the life of the heatgun.
- The heatgun is supplied with a thermal cut-off switch located internally near the heating element to prevent overheating. If your heatgun shuts-off during use, or fails to operate when turned to low or high position, be sure to turn it off, unplug it from the outlet and call a qualified service technician for assistance. You may only need to wait for it to cool down (normally several minutes) and then turn it back on so you can use it again. However, never leave the heatgun unattended; especially with the switch turned on or after it has experienced partial failure.

- When you are finished using the heatgun, stand it on its convenient stand with the nozzle pointing up. This method is the best and safest way to allow it to cool after use, and is the only way suggested for cooling of the heatgun between uses. Avoid laying heatgun on its side. Do not point the heatgun in a downward position when cooling! This may cause residual heat to rise back into the heatgun and damage internal components and cause the heatgun to malfunction.
- Nozzle gets extremely hot. Never touch nozzle to any surface during or shortly after operating. Keep away from combustibles.
- When storing the heatgun, allow it to cool completely (i.e. check the nozzle), and unplug it for storage.
- Never obstruct the hot airflow by blocking or covering the air outlet at nozzle or intake at back end of the heatgun and keep them clean and free of dirt and debris.
- Airflow is very hot. Never direct towards yourself, animals or others.
- Turn the switch off and disconnect the heatgun when not in use. Avoid unintentional starting.
- This heatgun is intended only for the purpose of shrinking plastic films. Any other attempted use is at your own risk.
- Keep the heatgun moving constantly. Lingering or pausing in one spot could burn or melt the shrinkfilm and/or your product.

HEATGUN CLEANING INSTRUCTIONS:

- Use only a damp cloth to wipe the gun clean. Never use turpentine, paint thinner, gasoline, or similar substances to clean the gun.

OPERATING INSTRUCTIONS

SHRINK WRAP SYSTEM

1. Plug power cord into 110VAC 15A wall outlet.
2. Turn power on by depressing rocker switch. No warm-up time is required.
3. Plug the heat gun into AC outlet on left hand side of box.
4. Separate film and place around spreader bar. (See Figure 1)

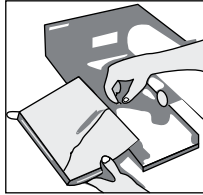



Figure 1

5. Pull film to the desired length on the left hand side of sealing arm and sealing pad. Open film and insert package. Roll excess film back onto the roll so that package is approximately even with edge of sealing pad.
6. Adjust dial to proper setting. Holding package in left hand, bring the sealing arm down firmly onto the film and pad until the LED indicator turns off. Gently pull package away in a tearing motion until package is completely separated from pad. Release the arm and turn the package counter-clockwise 90°. Repeat to seal the remaining edge of film. (See Figure 2)

 **NOTE:** If the cutting and sealing process takes longer than 3 to 5 seconds, turn up the dial on the machine. If this does not reduce the dwell time, call Uline for assistance at 1-800-295-5510.

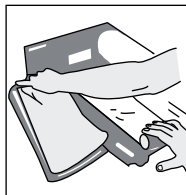

Figure 2

7. To shrink film around the product: adjust heat gun to desired temperature. Holding gun approximately 12" from product, begin to shrink film around the seams first and then toward the middle in a circular motion until package has a glass-like appearance. (See Figure 3)



NOTE: Do not hold gun in the same position for more than a few seconds. This will cause the film to burn rather than to shrink.



WARNING! Heat gun should not be left on when air intake vents are blocked or for a prolonged period of time to prevent overheating! Make certain that switch is in the off position to ensure that both the blower and heating element are shut off, or heat damage may occur.

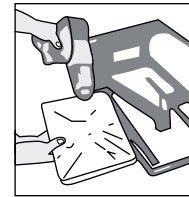

Figure 3

8. Always turn your Shrink Wrap System off when not in use.

TROUBLESHOOTING

OPERATING ISSUE	RECOMMENDATIONS
Centerfold shrink film will not separate or open.	If shrink film appears to be single sheet, place a strip of tape on top of the film and on the bottom and pull apart to initially separate.
Film appears to smoke or is sticking to wire when seal is made.	<p>This can mean one of several things:</p> <ol style="list-style-type: none"> 1. With PP or PO film, wire must be kept clean by removing sealing pad and depressing arm until wire burns clean all film residue. No teflon tape required on arm. 2. PVC film will smoke when seal is made. Teflon tape over the heating element will prevent the film from smoking and will occasionally need to be replaced. For teflon tape or other parts, call Uline at 1-800-295-5510.
Burning holes in shrink film with the heat gun.	If gun is set on high temperature and held in the same spot for more than a few seconds, the film will burn. Gun should be continually moving in a circular spiral motion from the outside edges of the package first, and to the middle of the package last.
Arm is not properly cutting and sealing shrink film.	<ol style="list-style-type: none"> 1. On/Off switch may not be turned on. 2. Timer on Industrial model may not be set properly. 3. Arm may not be in complete contact with pad. (Gentle Pressure). 4. Excessive pressure applied to sealing arm. 5. Wire may need cleaning.
Setting timer properly.	Timer should be set to allow the minimal amount of time necessary to cut and seal the film. The setting will vary according to type of film in use. Setting timer too high will burn the film. PVC film will require a lower setting than most other films. Timer may need to be adjusted to lower setting as machine is used in a continuous or rapid manner.
Package is ballooning when the film is heated.	<p>The air inside the package expands as the film is heated. The quickest way to vent the film is to cut an asterisk (*) into the closed end of the centerfold. The smaller your package, the more lines you should cut to make sure every package has at least one vent hole.</p> 