



IMPULSE SEALER

OPERATING INSTRUCTIONS

MODEL: H-161

H-163

H-190

H-293

H-306

H-458

H-963

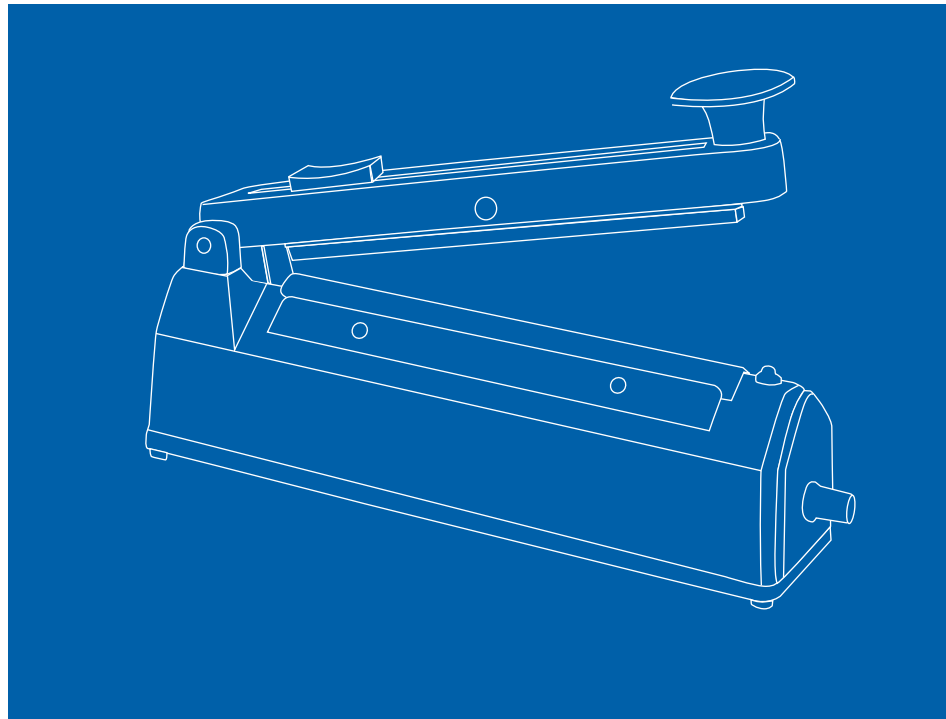

1

PARTS IDENTIFICATION

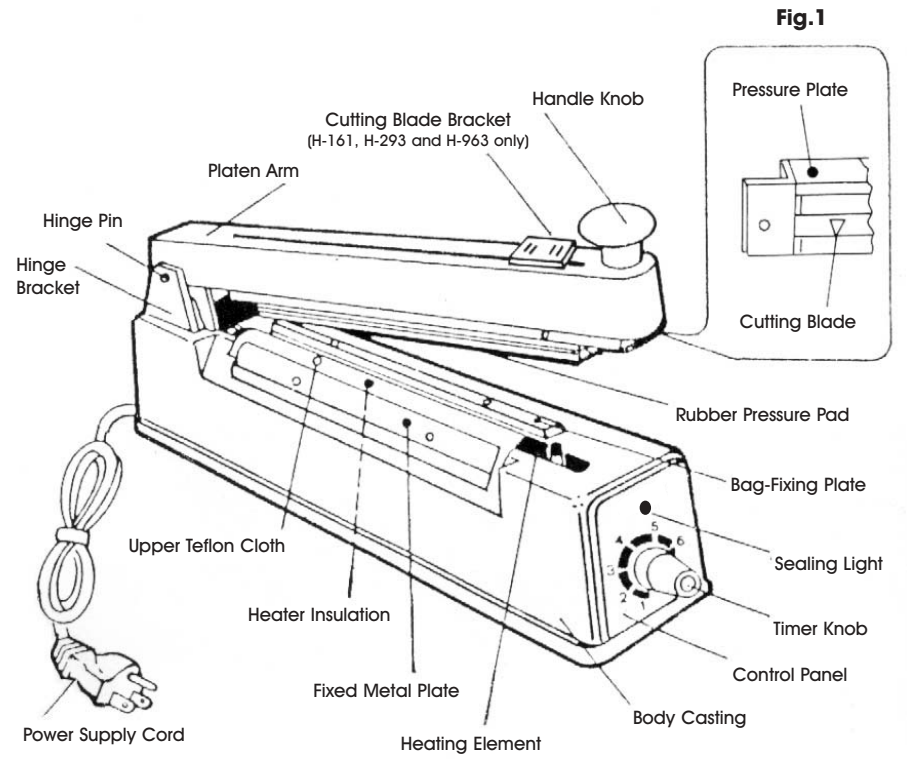

FIG. 1 (ONLY USE FOR H-161, H-293 AND H-963 MODELS)

1

PARTS IDENTIFICATION (CONT.)

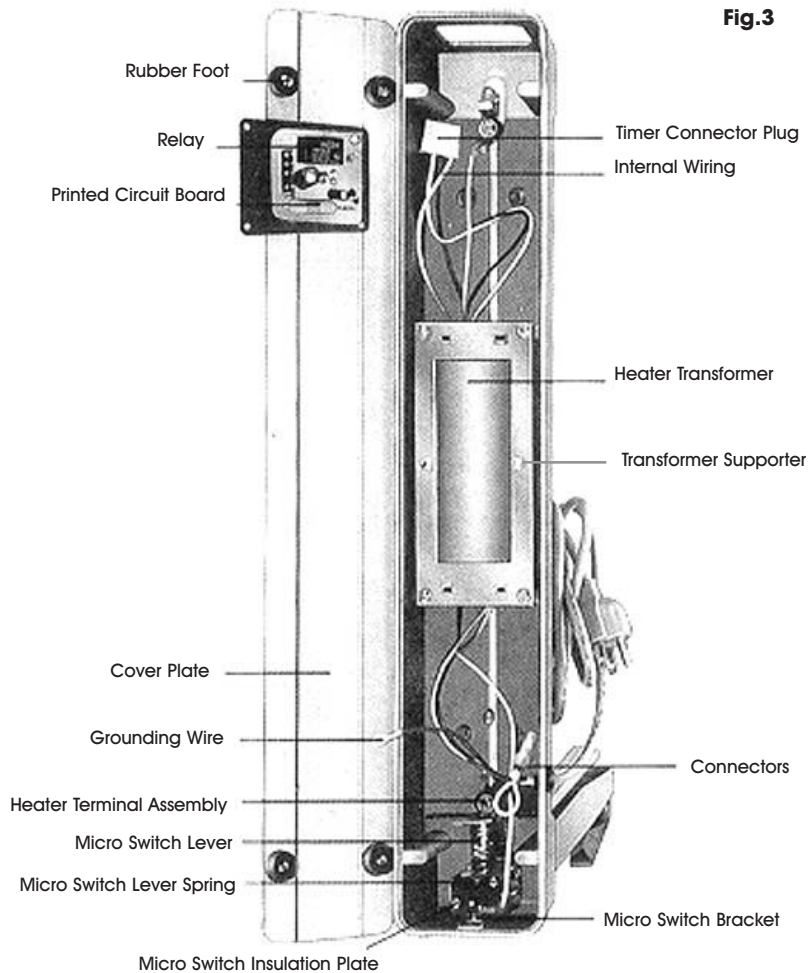
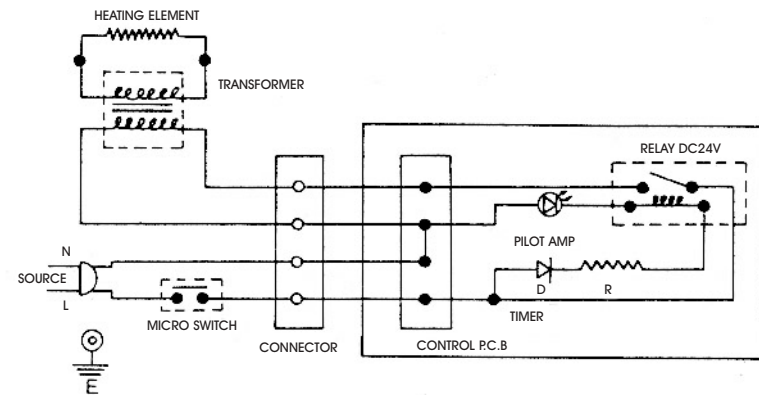

FIG. 3 (FOR ALL HAND SEALER MODELS)

2

CONNECTION DIAGRAM



3

OPERATION

- This machine does not have a power switch. Plug the power cord into the outlet and set the timer knob according to the thickness of the materials to be sealed. The higher the number on the dial, the longer the heat sealing time.
- Put one plastic bag on the sealing platform, and then push down the sealing arm. The sealer will automatically control the seal time. Power is off when the light turns off.
- After 1-2 seconds, slide the cutter (only on H-161, H-293 and H-963) to trim the bag, then release the sealing arm.
- If the bag seal is damaged or broken, the heating time is too long. Reset the timer knob to a lower number.
- If the plastic bag sticks to the sealing arm, there was not enough cooling time. Keep the arm down for a longer period of time after the light turns off.
- The unit can be left plugged in. The unit is off unless the sealing arm is down.

4

RECOMMENDED SETTINGS

- Recommended timer settings for ULINE Poly Bags

Sealer	1 Mil	2 Mil	3 Mil	4 Mil	6 Mil
H-161	3	3	3	4	5
H-163	3	3	3	4	5
H-190	3	3	3.5	4	5.5
H-293	3	3	3.5	4	5.5
H-306	3	3	3.5	4	5.5
H-458	3	3	3	4	5
H-963	3	3	3.5	4	5

5

NOTES

- Always keep the sealing platform clean.
- Do not use water to clean the sealing platform.
- A short circuit will occur if the bottom teflon cloth strip wears out. Each time you replace the heating element or the top teflon cover, check the bottom teflon tape for wear and damage.
- Only use ULINE replacement parts.
- A worn rubber pressure pad (under the handle) will influence the quality of the seals. The rubber pad should be periodically checked for uneven wear.

6

REPLACEMENT PARTS

MODEL	H-458	H-163	H-190	H-306	H-161	H-293	H-963
Repair Kit	H-471	H-164	H-191	H-307	H-495	H-294	H-964

7

SEALER SPECIFICATIONS

MODEL	H-458	H-163	H-190	H-306	H-161	H-293	H-963
Source	120v	120v	120v	120v	120v	120v	120v
Impulse Power	160w	260w	380w	600w	260w	450w	680w
Max. Seal Length	4"/100mm	8"/200mm	12"/300mm	16"/400mm	8"/200mm	12"/300mm	16"/400mm
Max. Seal Thickness	6 Mil	12 Mil	6 Mil	6 Mil	12 Mil	6 Mil	6 Mil
Weight	3.7 lb	5.8 lb	8.5 lb	9.9 lb	7.7 lb	10.1 lb	11.9 lb
Dimensions	2.8 x 8.3 x 5.9 IN	3.2 x 12.6 x 5.9 IN	3.3 x 17.8 x 7.4 IN	3 x 21 x 7 IN	3.2 x 15 x 6.3 IN	3.2 x 17.9 x 7.4 IN	3.2 x 21.8 x 7.3 IN



1-800-295-5510

CHICAGO • MINNEAPOLIS • LOS ANGELES • NEWARK • ATLANTA