

# ULINE INDUSTRIAL STEEL SHELVING

1-800-295-5510  
uline.com

## TOOLS NEEDED



11mm Wrench

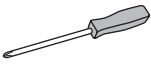

Phillips  
Screwdriver



Step Ladder  
(optional)

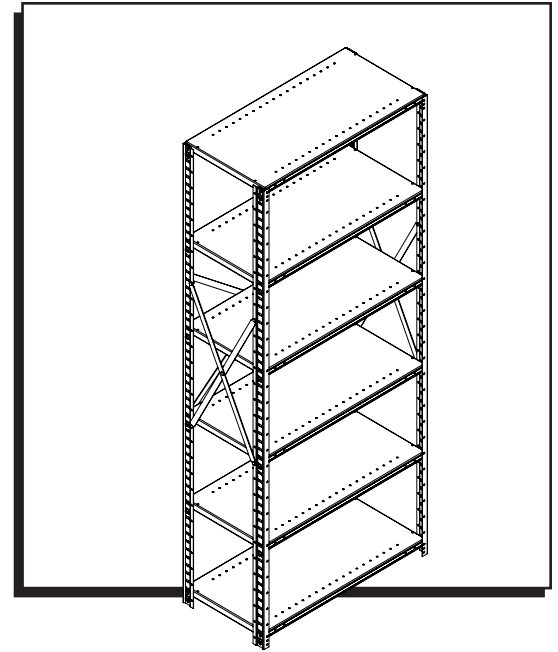

## PARTS

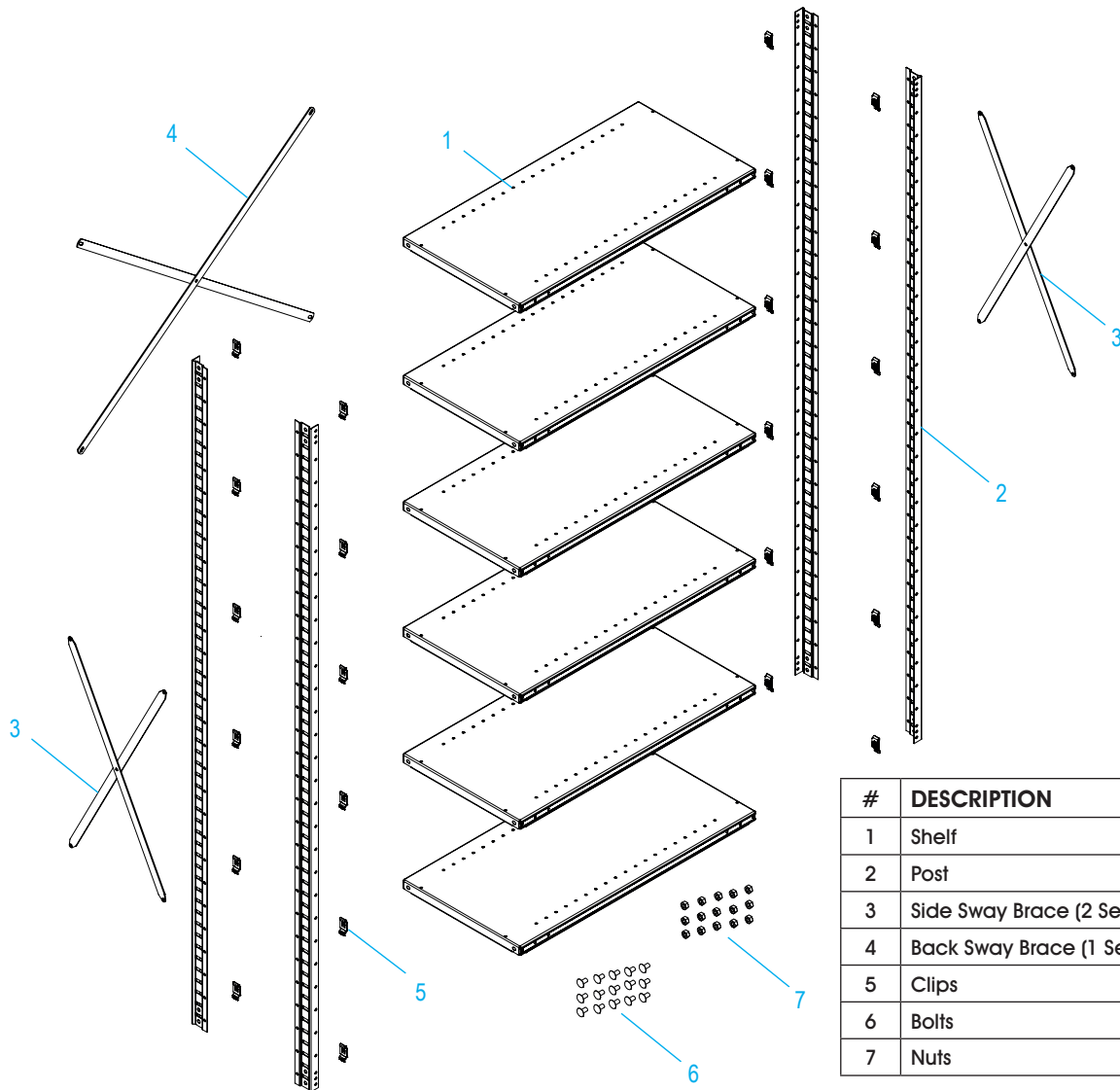

#	DESCRIPTION	QTY.
1	Shelf	6
2	Post	4
3	Side Sway Brace (2 Sets)	4
4	Back Sway Brace (1 Set)	2
5	Clips	24
6	Bolts	15
7	Nuts	15

# INSTRUCTIONS

Step 1

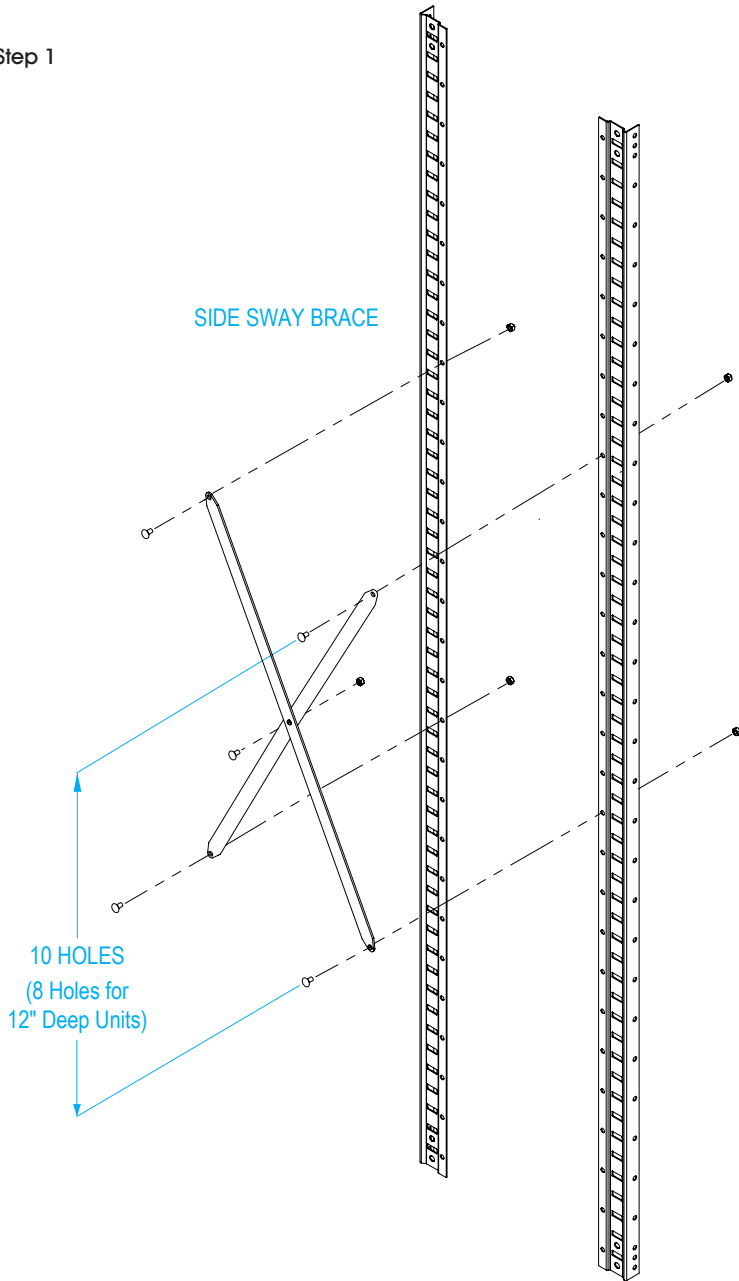

1. Center side sway braces and affix to posts.



**NOTE:** Do not fully tighten nuts and bolts.



**NOTE:** For 12" deep units (H-3841, H-3842, H-3843, H-3844), side sway braces must be 8 holes apart.

Step 2

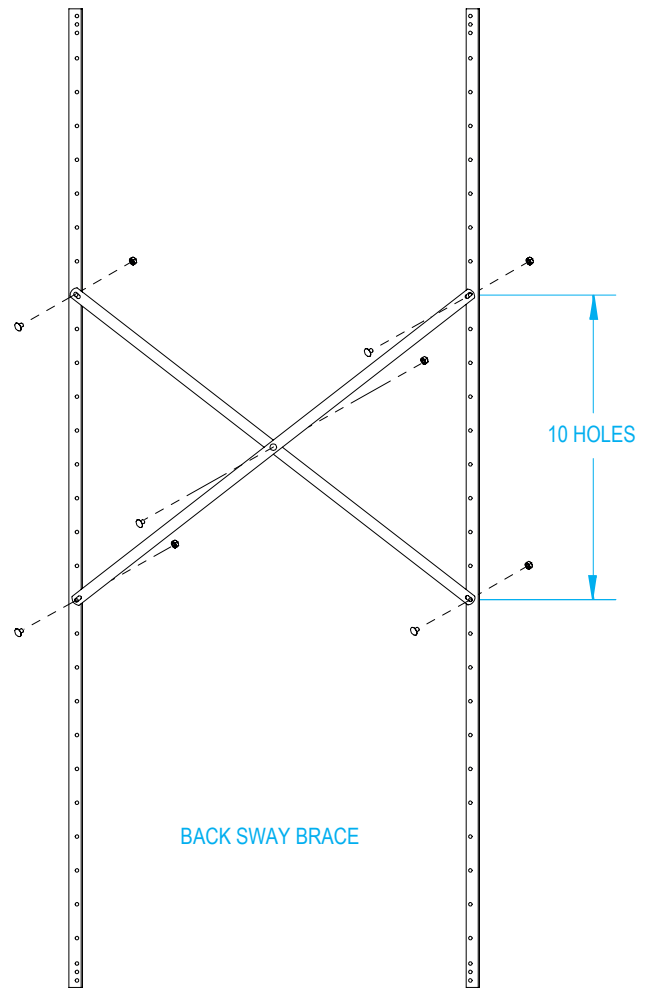

2. Center back sway brace and affix to posts.

## INSTRUCTIONS CONTINUED

Step 3

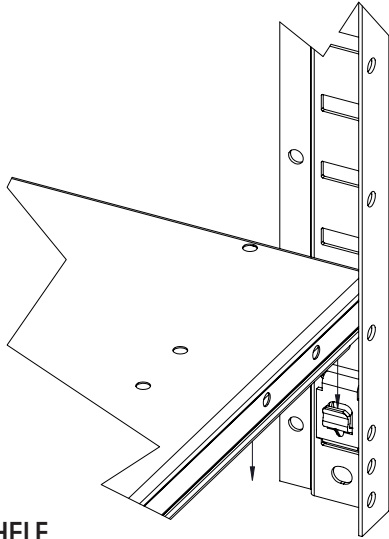

### BOTTOM SHELF

1. Insert clips into the first two bottom slots of the posts.
2. Insert the shelf into the clips.

Step 4

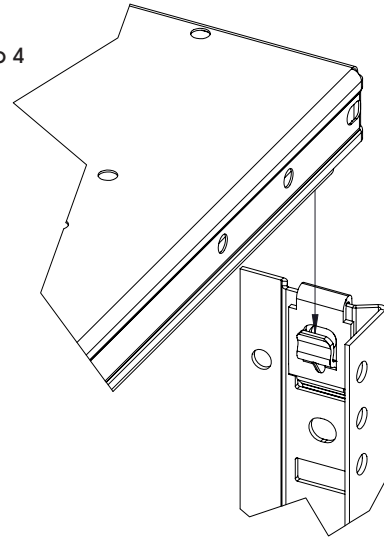

### TOP SHELF

1. Insert clips into the top and last slot of the posts.
2. Insert the shelf into the clips.

Step 5

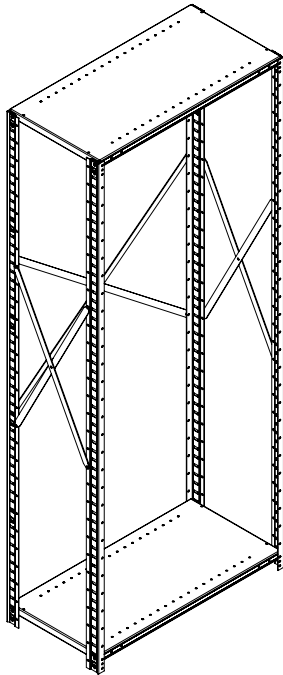

1. Make sure all bolts are fully tightened.

Step 6

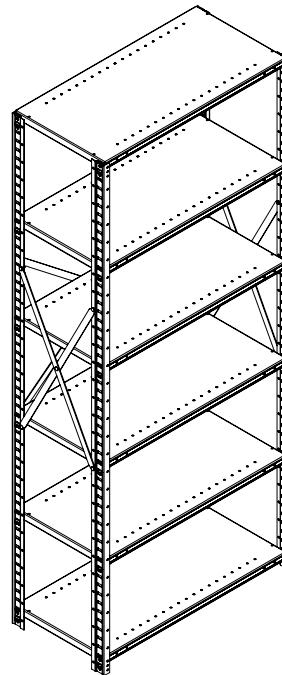

1. Insert remaining clips at desired shelf heights.
2. Insert remaining shelves into the clips.