

ULINE H-3107, H-3108
WARDROBE CABINET

1-800-295-5510
uline.com

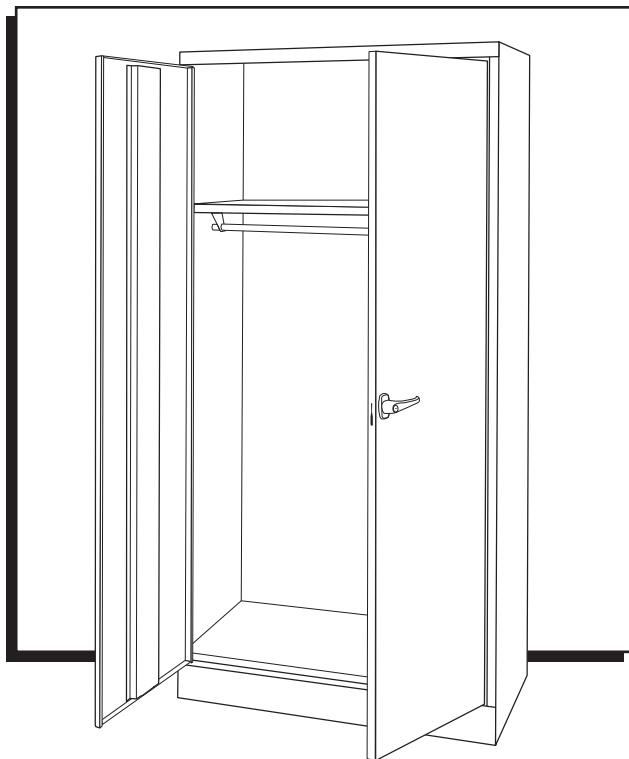

TOOLS NEEDED

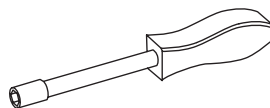

1 1/32" Nut Driver
(included)

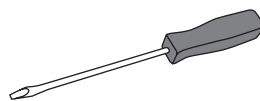

Flathead Screwdriver

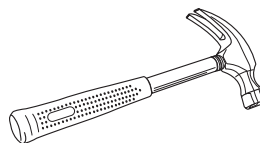

Hammer



CAUTION! Some parts may have sharp edges. Take care when handling various pieces to avoid injury. For your safety, wear work gloves when assembling.

PARTS

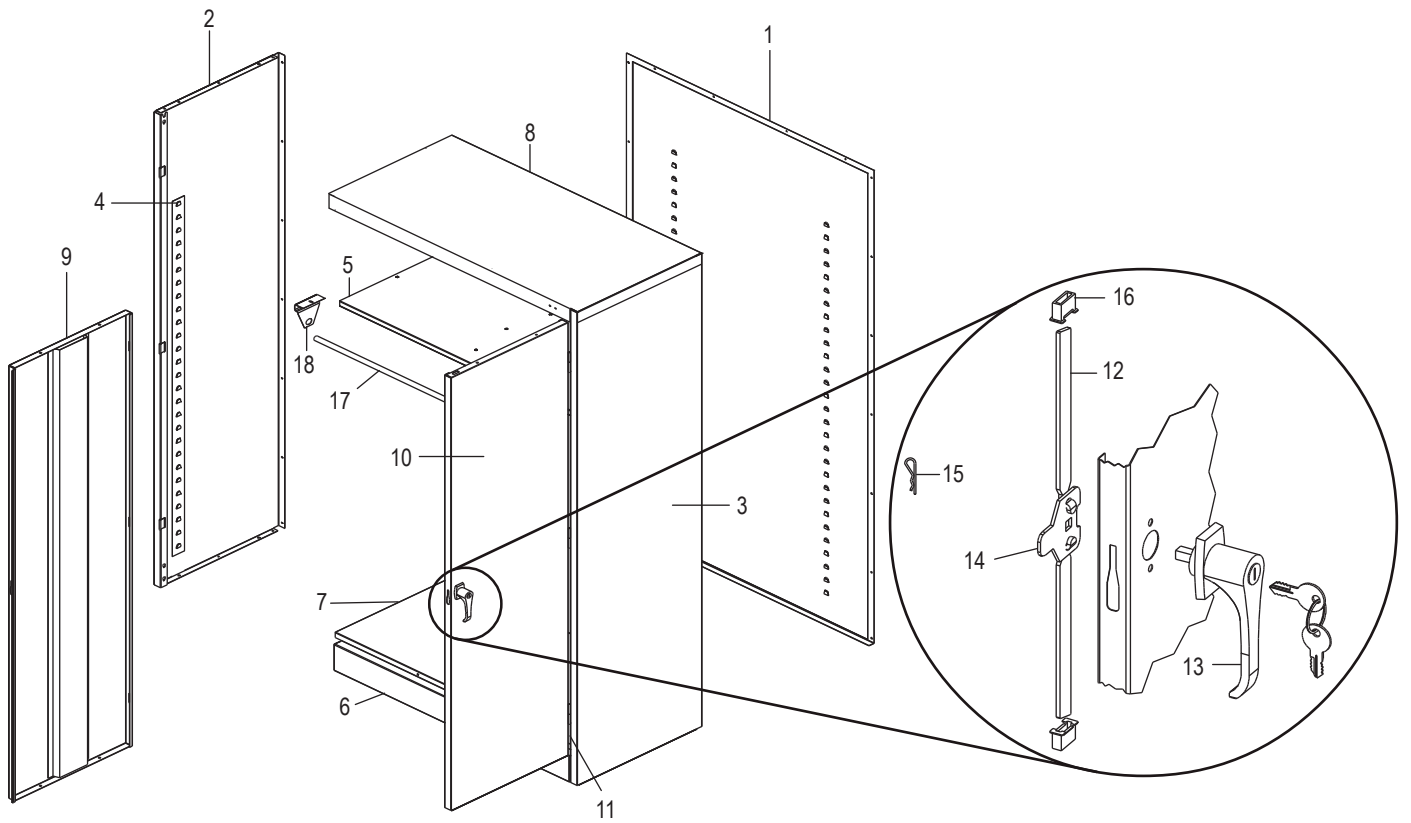

PRIMARY ASSEMBLY

HANDLE ASSEMBLY

#	DESCRIPTION	QTY.
1	Back Panel	1
2	Left Side	1
3	Right Side	1
4	Lance	N/A
5	Shelf	1
6	Sill	1
7	Bottom	1
8	Top	1
9	Left Door	1
10	Right Door	1

#	DESCRIPTION	QTY.
11	Hinge Pin	6
12	Lock Bar	2
13	Locking Handle with Keys and Hardware	1
14	Locking Cam	1
15	Cotter Pin	1
16	Locking Bar Guide Insert	2
17	Coat Rod	1
18	Coat Rod Bracket	2
	#8-32 x 3/8" Bolt (Not Shown)	31
	#8-32 Nut (Not Shown)	47

ASSEMBLY INSTRUCTIONS

ASSEMBLING CABINET

1. Place the back (1) on a protected surface. The bottom flange should be facing upward.
2. Attach the left side (2) and right side (3) to the back by placing flange around the back and bolting the back and sides together with seven bolts and nuts on each side. Be sure that the lances (4) on all shelf adjustment strips point in the same direction. (See Figure 1)

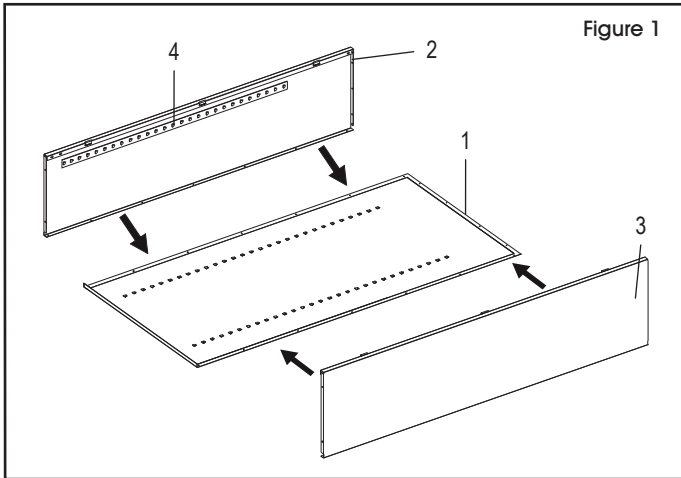

3. To help hold the sides in position, insert the shelf (5) into the top position of the shelf adjustment strips, inserting the shelf edges into the lances on all four shelf adjustment strips. Be sure that the channeled edge of the shelf is toward the cabinet front. (See Figure 2)

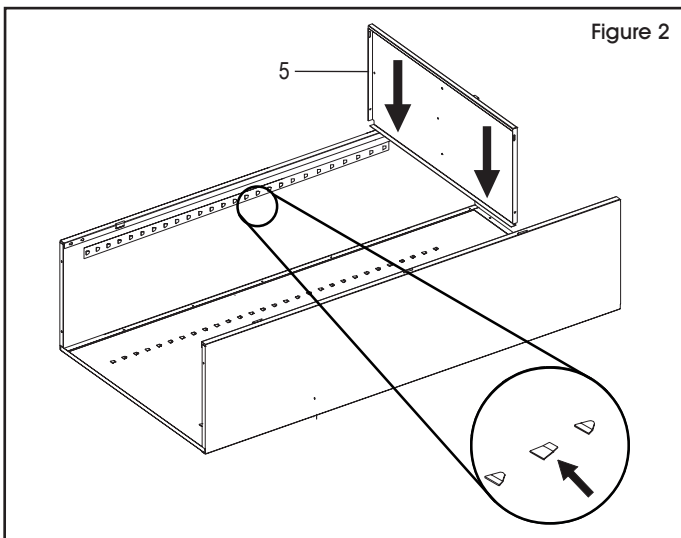

4. Attach the top (8) to the unit by sliding the outer flange over the back of the unit and the side flange on the side panel of the unit. The threaded studs should go through the holes in the top flange of the side and fasten with three nuts. Attach the back to the top using four bolts and nuts. (See Figure 3)

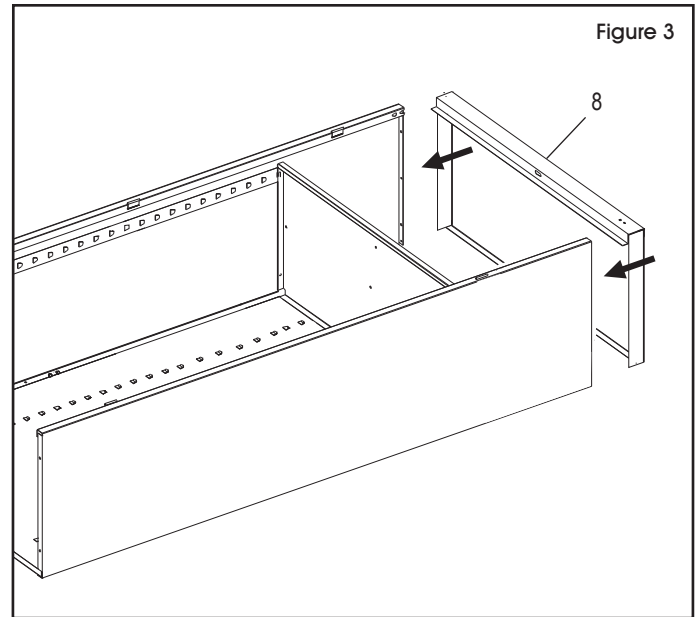

5. Attach the sill (6) to the two holes on each side of the cabinet bottom. Flange faces upward. (See Figure 4)

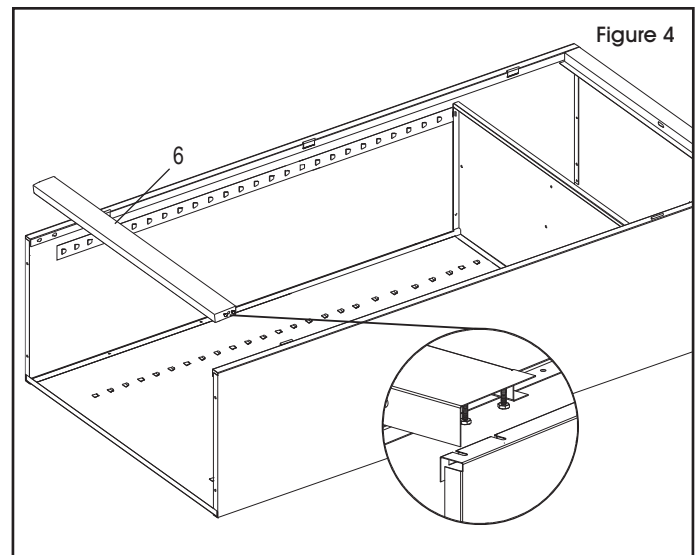

ASSEMBLY INSTRUCTIONS CONTINUED

6. Place the bottom (7) in the bottom lances of the shelf adjustment strips. The flange with two holes should face the front, and it should hang over the sill. Bolt to the sill with two bolts and nuts. (See Figure 5)

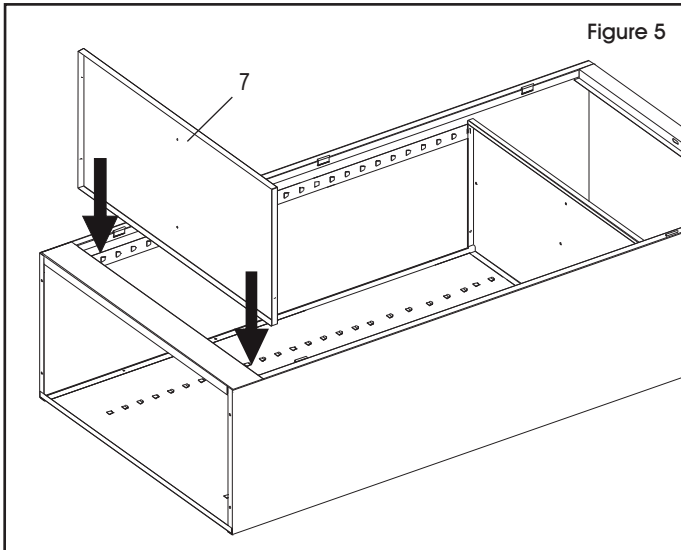

7. Set the unit upright and attach a coat rod bracket (18) beneath the left side of the cabinet shelf by inserting one bolt through the hole in the left edge of the shelf. Secure with a nut. Attach the right bracket in the same way. Slide the coat rod (17) through holes in the brackets. (See Figure 6)

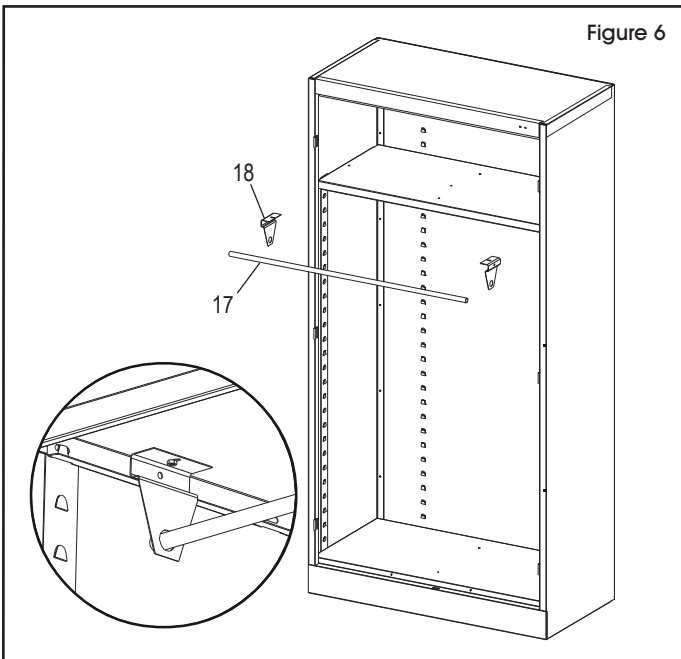

8. Attach the doors (9) and (10) to the unit by placing the door on the hinges, aligning the holes, and using a hammer to tap the hinge pins (11) into place with the side of a screwdriver. (See Figure 7)

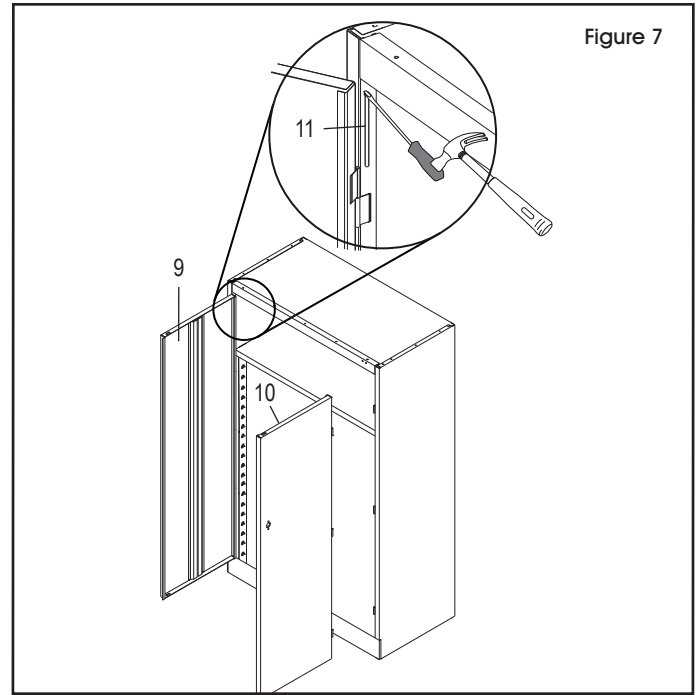

ASSEMBLY INSTRUCTIONS CONTINUED

ATTACHING HANDLE

1. Place the door handle (13) on the right hand door and fasten with two slotted bolts and lockwashers. (See Figure 8)

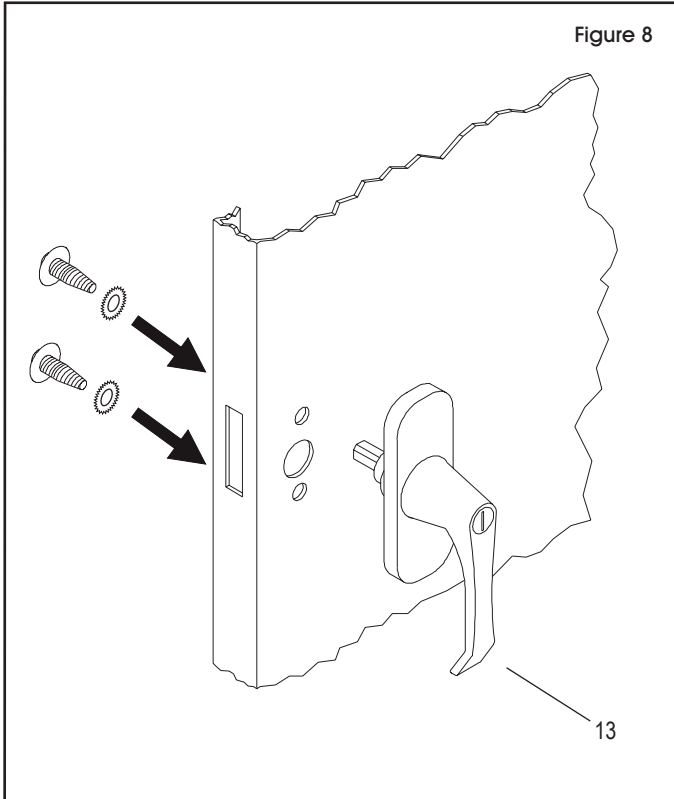

2. Turn the handle to the open position (parallel to the ground) and hook the lock bars (12) to the locking cam (14). (See Figure 9)
3. With the handle still in the open position, place the locking cam (14) over the square shank of the door handle. The locking cam must be facing downward as shown. (See Figure 9)
4. Hold the lock bars in position while sliding the lock bar guides (16) over the ends of the lock bars and through the door slots. (See Figure 9)

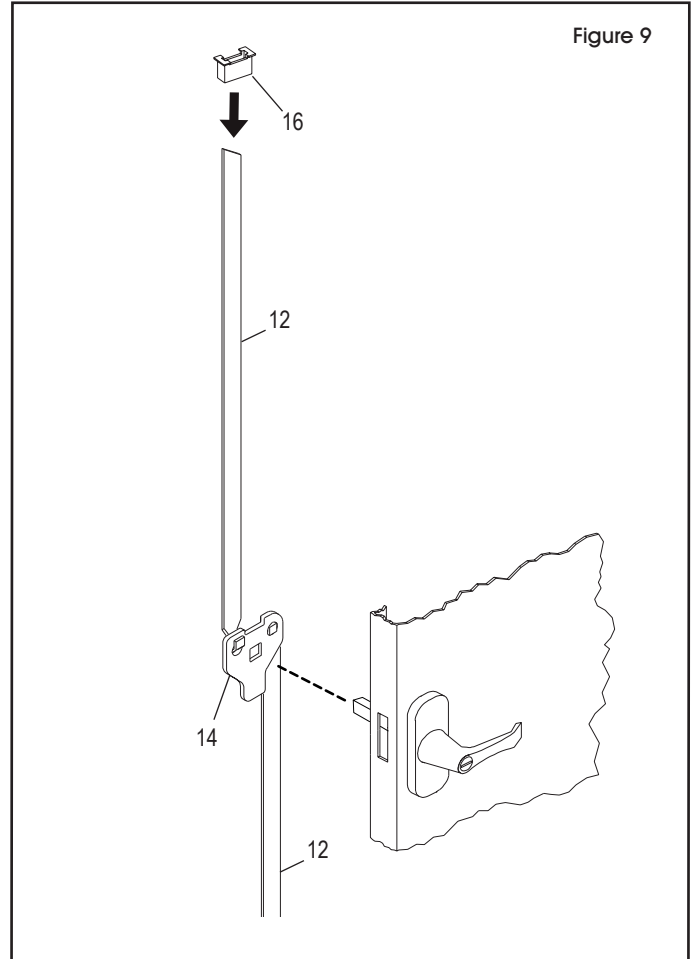

5. Place the cotter pin (15) through the hole of the square shank. (See Figure 10)

