

BOOKCASE – UNASSEMBLED

TOOLS NEEDED

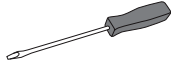

Rubber Mallet



Flat Head
Screwdriver



PARTS

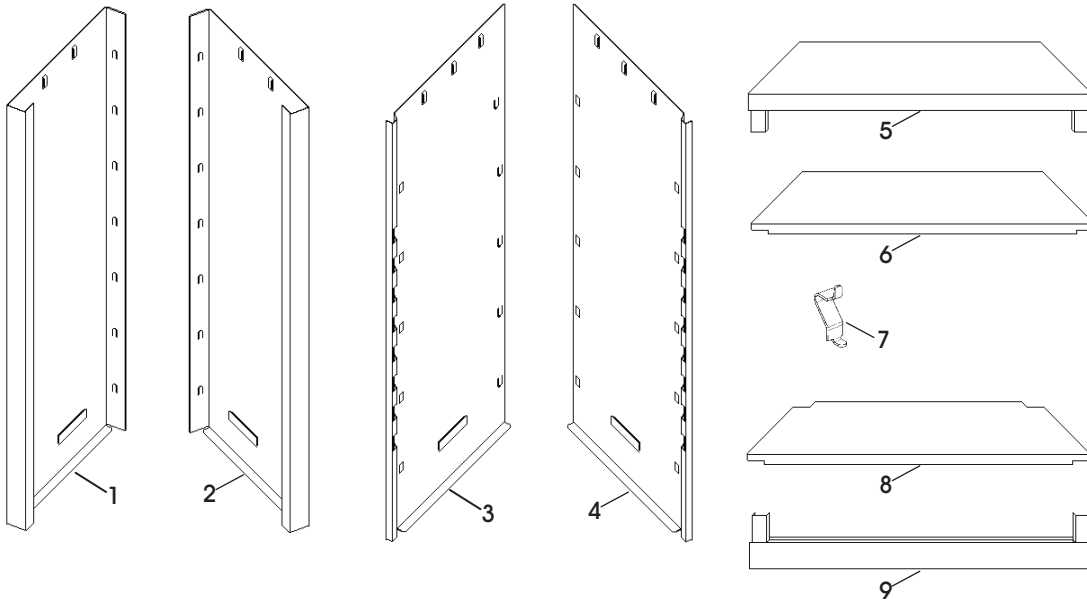

#	DESCRIPTION	QTY 3 SHELF	QTY 4 SHELF	QTY 5 SHELF
1	Left Side Panel	1	1	1
2	Right Side Panel	1	1	1
3	Left Back Panel	1	1	1
4	Right Back Panel	1	1	1
5	Top	1	1	1
6	Center Shelf	2	3	4
7	Shelf Clip	4	6	8
8	Bottom Shelf	1	1	1
9	Kick Plate	1	1	1

SAFETY



CAUTION: Use caution when handling and assembling metal parts. Metal may have sharp edges or corners. Use of protective gloves is recommended when assembling product.



NOTE: Assemble the unit on level surface. 2-person assembly is recommended.

- Do not exceed the recommended weight capacity of 120 lbs. on each shelf. Always distribute weight evenly on shelves.
- Storing heavier items on lower shelves is recommended.

ASSEMBLY

BACK ASSEMBLY

1. Lay the two back panels on a flat surface. (See Figure 1)
2. Place the right back panel (4) over the left back panel (3), inserting the locking tabs into the matching square holes. (See Figure 1)



NOTE: Locking tabs can be adjusted open or closed with a screwdriver to ease assembly.

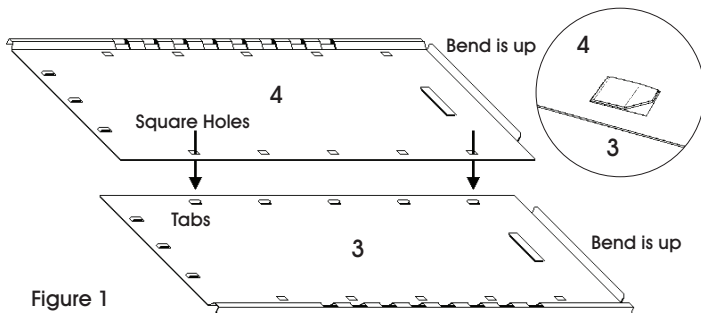

Figure 1

3. Once all the locking tabs are placed into square holes, slide the back panels in opposite directions to fully engage the tabs. (See Figure 2)

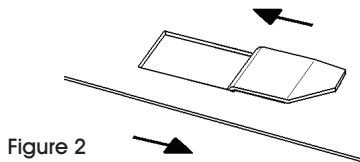

Figure 2

4. Tap the locking tabs down with a rubber mallet to tighten the connections.

SIDE ASSEMBLY

1. With the back panels laying on a flat surface, lift the outside edge of the right back panel (4) and slide the L-shaped bend of the right side panel (2) under it. (See Figure 3)
2. Insert locking tabs on the right side panel (2) into the matching square holes in the right back panel (4). (See Figure 3)

3. Once all locking tabs are placed into square holes, slide the side and back panels in opposite directions to fully engage the locking tabs.

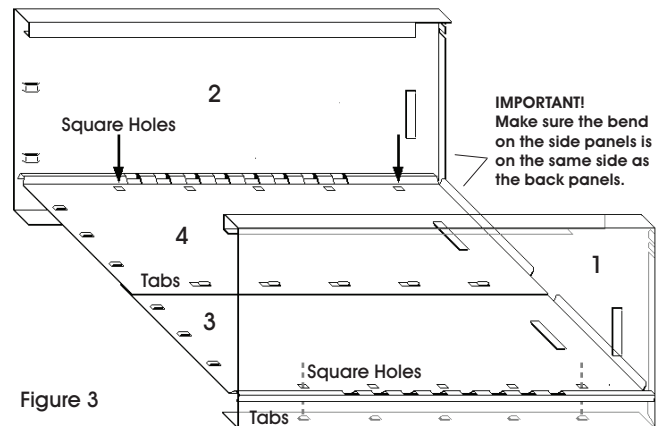

Figure 3

4. Tap each of the locking tabs down with a rubber mallet to tighten the connections.
5. Repeat steps one through four with the left side panel (1).

BOTTOM ASSEMBLY

1. Position the kick plate (9) as illustrated and begin installation by lifting its right end upwards inside the channel on the right side panel (2). (See Figure 4)
2. Push the kick plate upwards until the crescent tab on the side panel engages the square hole on the kick plate. (See Figure 4)



NOTE: Ensure a tight fit. A loose connection would result in an unstable unit.

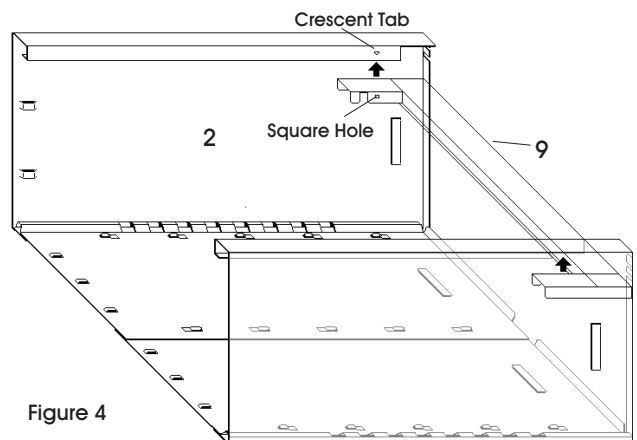

Figure 4

ASSEMBLY CONTINUED

- Using a flat head screwdriver, bend the tab on the bottom of the side panel 45° inward to lock the kick plate in place. (See Figure 5)

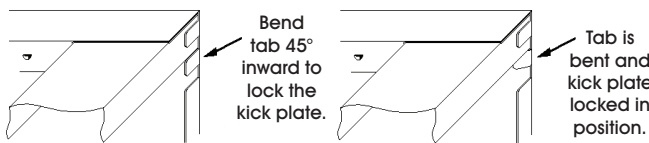

Figure 5

- Repeat steps one through three for the left side of the kick plate.
- Install the bottom shelf (8) by placing it in the bookcase with the notched corners toward the back panels. (See Figure 6)
- Angle the bottom shelf and engage the supports located on the two back panels. (See Figure 6)

NOTE: As with the locking tabs, some adjustment to the supports on the side and back panels using the screwdriver may be necessary.

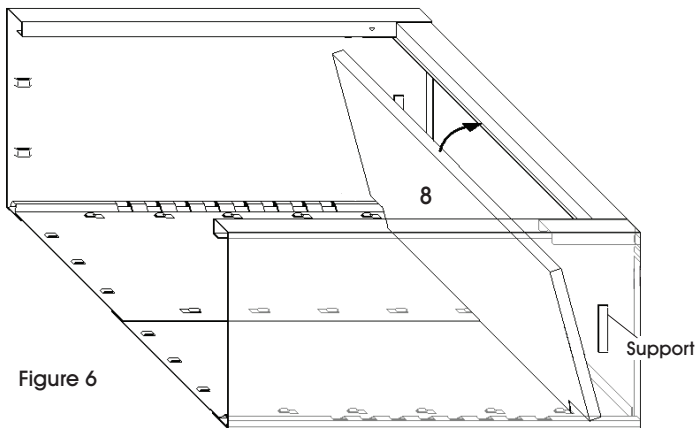

Figure 6

- Gradually tilt the front edge of the bottom shelf forward, making sure that it engages the supports located on the right and left side panels and goes over the bend on the front of the kick plate.

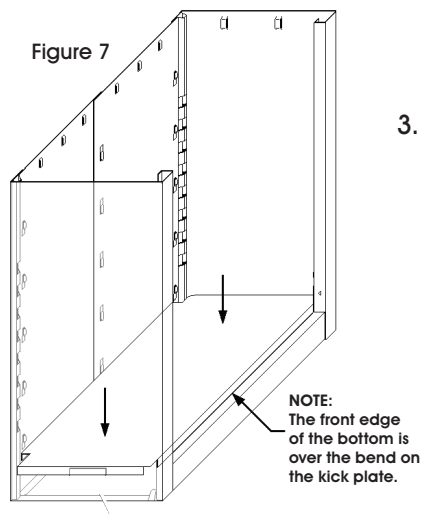

Figure 7

- Carefully stand the unit upright and tap the bottom shelf down. Make sure bottom shelf is securely positioned on the supports on the back and side panels. (See Figure 7)

TOP ASSEMBLY

- Begin inserting the posts on the top (5) into the channels on the right and left side panels. (See Figure 8)

NOTE: Starting with the top on a slight angle might help.

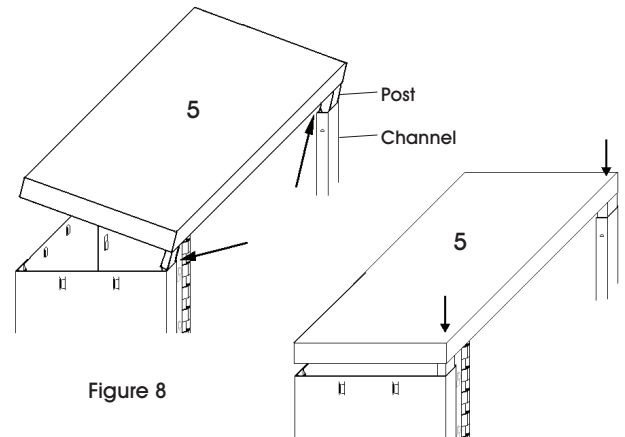

Figure 8

- Once both posts are started, tap evenly down on the top (5) with a rubber mallet until it is just past the side and back panels. (See Figure 9)

NOTE: Make sure the top is going over the side and back panels.

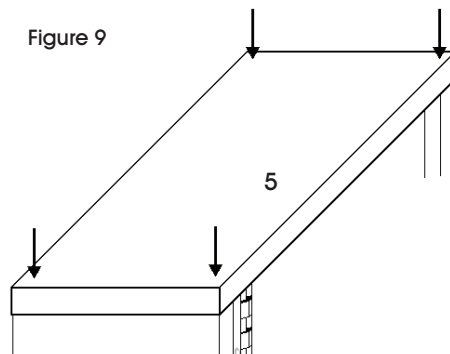

Figure 9

- Check under the top to make certain that the side and back panels are inside the supports. (See Figure 10)

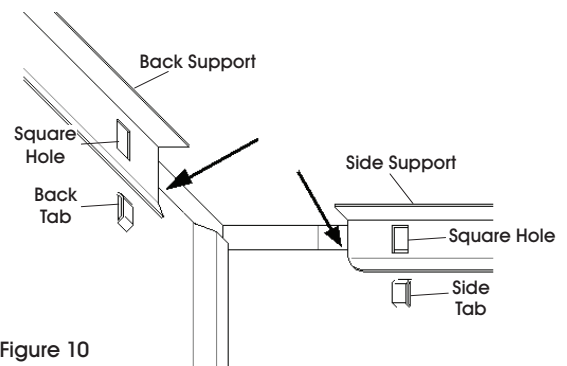
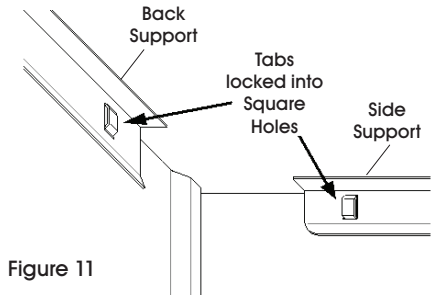

Figure 10

ASSEMBLY CONTINUED

4. Tap the top down around the edges with a rubber mallet until the locking tabs on the side and back panels snap into the square holes on the supports. (See Figure 11)



CENTER SHELF INSTALLATION

1. At the desired shelf height, insert 2 shelf clips (7) into the holes located inside the front edges of the side panels. (See Figure 12)

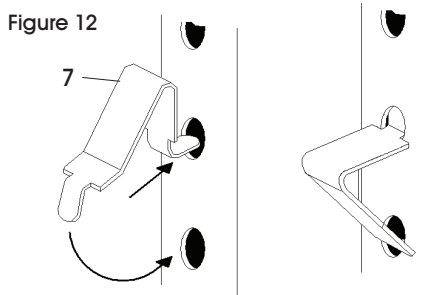

2. Angle a shelf (6) into the cabinet above the installed clips with its rear tilted down. (See Figure 13)
3. Insert the rear of the shelf into the slots in the back panels that are closest in height to the installed clips. (See Figure 13)

4. Tilt the shelf down until it rests on the shelf clips. If the shelf is uneven, reposition the shelf clips into appropriate locations to level it. (See Figure 13)

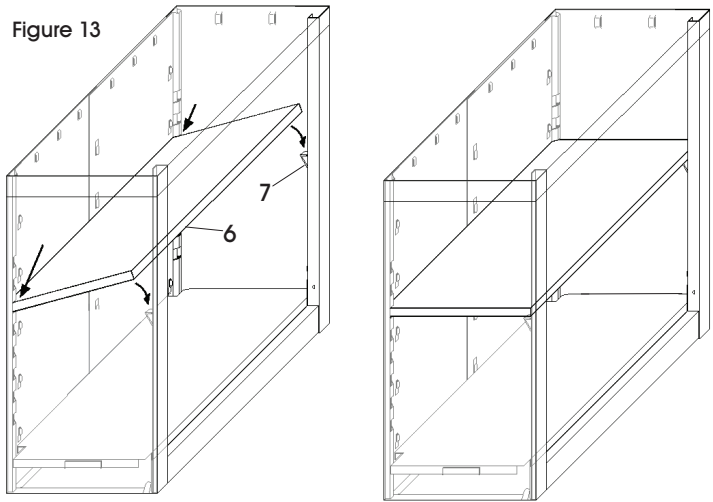

5. Repeat this process for all of the center shelves.

 **NOTE:** After assembly is complete, mild soap and water can be used to clean the unit by wiping with a soft cloth.