

# ULINE H-2549 SANITAIRE® UPRIGHT VACUUM

1-800-295-5510  
uline.com

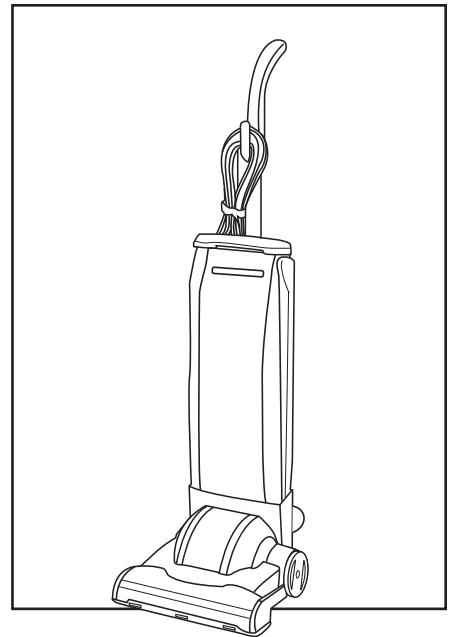

## MOTOR AND BASE

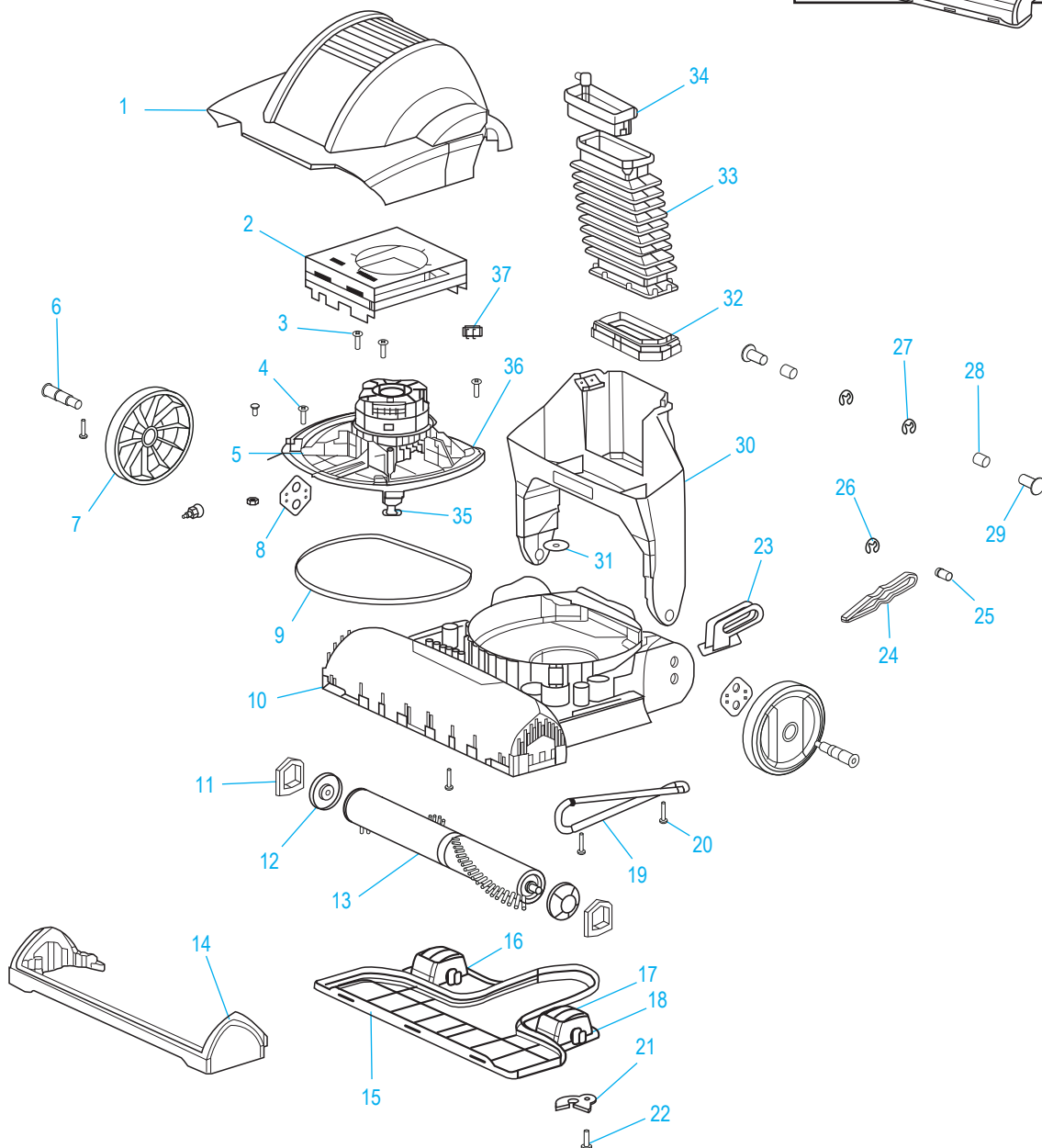

**ULINE** H-2549  
**SANITAIRE**<sup>®</sup>  
**UPRIGHT VACUUM**

1-800-295-5510  
 uline.com

MOTOR AND BASE PARTS LIST

#	DESCRIPTION	QTY.	ULINE PART NO.	MFG. PART NO.
1	Hood	1	-----	84823-308N
2	Air Separator Assembly	1	-----	78375
3	Screw Package	1	-----	53238-11
4	Screw Package	1	-----	53238-14
5	Motor Assembly - Cartoned	1	H-2549-53349	53349-9
6	Axle - Rear	1	-----	84554
7	Rear Wheel Assembly	1	H-2549-78365	78365
8	Bracket - Wheel	1	H-2549-78685	78685
9	Gasket - Motor Seal	1	H-2549-30517	30517
10	Base and Graphics Assembly	1	H-2549-78363	78363-5SV
11	Cap - Cover	2	H-2549-26059	26059A
12	Cap and Bearing Assembly	2	H-2549-38138	38138
13	Disturbulator Replacement	1	H-2549-54104	54104-2
14	Furniture Guard	1	H-2549-15	78380-355N
15	Bottom Plate Assembly	1	H-2549-16	79487SV
16	Package - Retaining Ring	1	-----	54432-4
17	Front Wheel Assembly	1	H-2549-18	79246-119N
18	Axle - Front	1	H-2549-19	78914
19	Belt Package Assembly (Upright)	1	H-2549-52100	52100B
20	Screw Package	1	-----	53238-27
21	Lock - Cam	1	-----	26295
22	Screw Package	10	-----	53143
23	Detent Base	1	H-2549-24	84824-16N
24	Detent Arm	1	H-2549-25	84825-355N
25	Pivot Pin	1	-----	84826
26	E-Clip	1	-----	85104
27	Package - Retaining Ring	1	-----	54432-3
28	Bushing - Yoke	1	-----	78689-119N
29	Axle - Yoke	1	H-2549-78688	78688
30	Yoke	1	-----	78367C
31	Washer	1	-----	79740
32	Clamp	1	-----	26266-3
33	Bellows	1	H-2549-78755	78755-380N
34	Retainer - Bellows	1	-----	83138-355N
35	Pulley - Motor Drive	1	-----	37012-2
36	Fan - Blower Motor	1	-----	81092
37	Clip - Wire	1	-----	55015
	Lock - Cam (Not Shown)	1	-----	26295
	Screw Package (Not Shown)	10	-----	53143
	Package - Retaining Ring (Not Shown)	1	H-2549-54432	54432-5

**ULINE H-2549**  
**SANITAIRE®**  
**UPRIGHT VACUUM**

1-800-295-5510  
 uline.com

BAG AND HANDLE

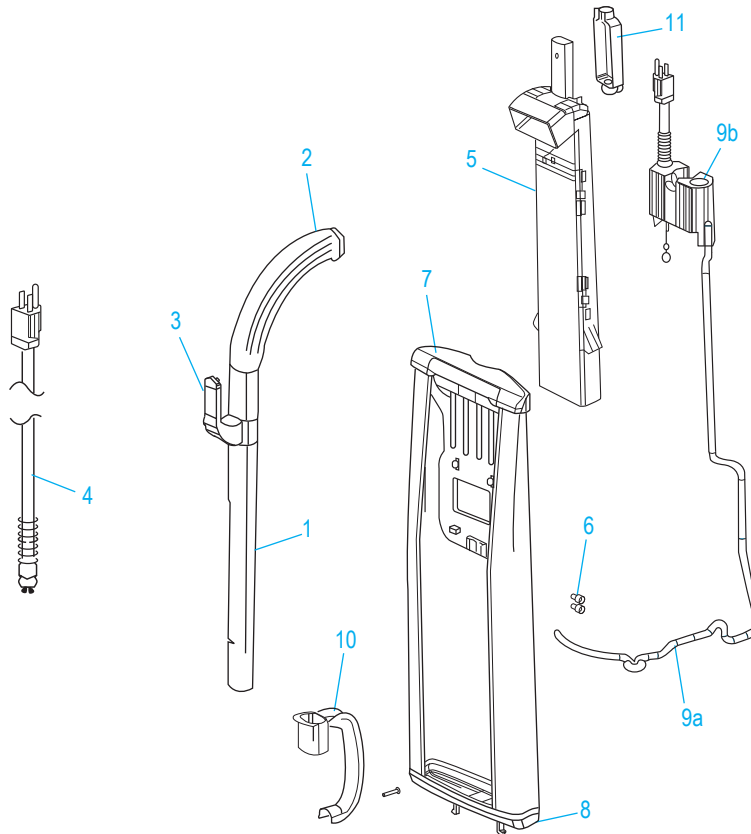

#	DESCRIPTION	QTY.	ULINE PART NO.	MFG. PART NO.
1	Upper Handle Assembly	1	H-2549-73832	78382SV
2	Grip - Handle	1	H-2549-78753	78753-380N
3	Cord Hook	1	H-2549-HOOK	79103-355N
4	Cord - Extension (50 Ft)	1	H-2549-76224	76224
4	Cord - Extension (50 Ft) (Older Style)	1	H-2549-80113	80113
5	Tube - Handle (Lower)	1	H-2549-83296	83296-355N
6	Wire Splice 5	1	-----	58313
7	Zipper Bag Assembly - Package	1	-----	53469-33
8	Retainer - Bag	1	H-2549-RETBG	78394-355N
9a	Switch Box Assembly	1	H-2549-80602	80602
9b	Switch - 2 Position (Round)	1	H-2549-76621	76621
10	Carry Handle	1	H-2549-79034	79034-355N
11	Cord Lock	1	-----	76225-355N
	Grip & Chain Assembly (Not Shown)	1	-----	79584SV
	Accessory Pak (Not Shown)	1	H-2549-HDWR	80213B
	Owner's Guide (Not Shown)	1	-----	80327B
	Synthetic Bag (Not Shown)	1	-----	79828
	Bag Pkg Assembly - Z Synthetic (Not Shown)	5	S-15820	63881
	Paper Bag - Style Z (Not Shown)	3	-----	52339A-6