

ULINE H-3579, H-4702

CLARKE® FLOOR CLEANING MACHINE

1-800-295-5510
uline.com

Pour le français, consulter les pages 5-8.

PRIMARY ASSEMBLY

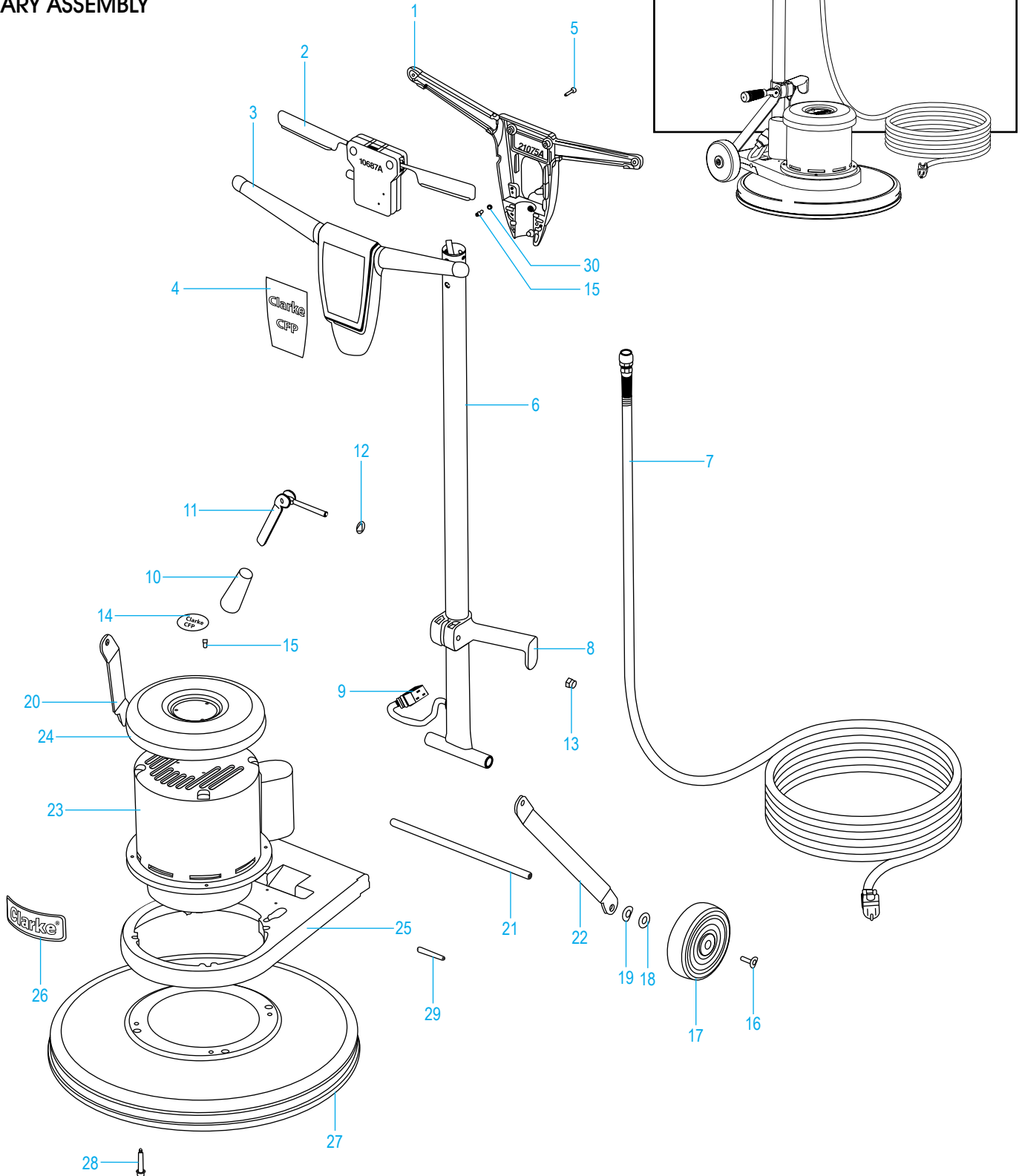

ULINE H-3579, H-4702**CLARKE® FLOOR
CLEANING MACHINE**

1-800-295-5510

uline.com

#	DESCRIPTION	QTY.	ULINE PART NO.	MFG. PART NO.
1	Handle, Back	1	-----	21075A
2	Module, Interlock	1	-----	10687A
3	Handle, Front	1	-----	21074A
4	Label, Handle	1	-----	71020A
5	Screw, 10-32 x 3/4"	6	-----	80284A
6	Tube, Handle	1	H-3579-THAND	61373A
7	Cord, 14/3 x 50'	1	-----	40788A
	Cord, Strain Relief (Not Shown)	1	-----	467504
	Cord, Terminal FIFQD (Not Shown)	2	-----	47711A
8	Clamp, Handle	1	H-3579-CHAND	50781A
9	Cord, Interconnect	1	-----	40789A
10	Grip, Handle	1	-----	56057675
11	Cam, Assembly	1	-----	441401
	Cam Lock Bolt (Not Shown)	1	-----	441301
	Cam, Locking (Not Shown)	1	-----	461404
	Pin, Coiled (Not Shown)	1	-----	53662A
12	Washer, Wear	1	-----	980349
13	Nut, 3/8" - 16 ESNA	1	-----	920342
14	Label (CFP-1700)	1	-----	71023A
14	Label (CFP-2000)	1	-----	71027A
15	Screw, 10-32 x 3/8"	5	-----	80290A
16	Screw, 1/4-20 x 1"	2	-----	80292A
17	Wheel	2	-----	56201018
18	Washer, 17/32 x 1 1/16" Plain	2	-----	980648
19	Washer, Bowed	2	-----	80295A
20	Link Arm - Right	1	-----	61741A
21	Axle	1	-----	61725A
22	Link Arm - Left	1	-----	61740A
23A	Motor (See Page 3)	1	H-3581	40763A
23B	Gearbox (See Page 4)	1	-----	53646A
24	Drip Cover	1	-----	61716A
25	Mainframe	1	-----	21088A
26	Label, Motor Clarke	1	-----	73323A
27	Housing, Assembly (CFP-1700)	1	-----	11006A
	Housing (CFP-1700)	1	-----	61715A
	Bumper (CFP-1700)	1	-----	30381A
27	Housing, Assembly (CFP-2000)	1	-----	11007A
	Housing (CFP-2000)	1	-----	61714A
	Bumper (CFP-2000)	1	-----	50784A
28	Screw, 5/16" - 18	4	-----	80294A
29	Pin, Split 1/2"	2	-----	53833A
30	Washer, Flat #10	1	-----	80291A
	Pad Driver (CFP-1700) (Not Shown)	1	-----	30638A
	Pad Driver (CFP-2000) (Not Shown)	1	-----	30639A

ULINE H-3579, H-4702

**CLARKE® FLOOR
CLEANING MACHINE**

1-800-295-5510

uline.com

MOTOR ASSEMBLY

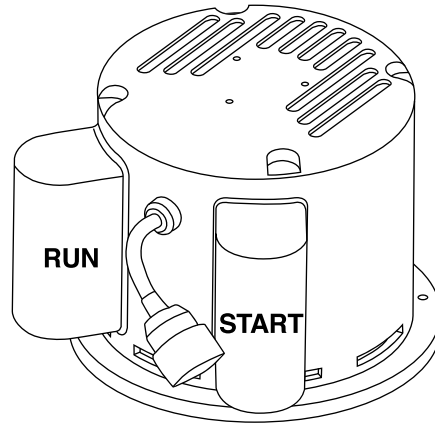

DESCRIPTION	QTY.	ULINE PART NO.	MFG. PART NO.
Rotor, 1.5HP, 60Hz	1	-----	53193A
Capacitor, Start	1	-----	40694A
Capacitor, Run	1	-----	53191A
Stator, 1.5HP, 60Hz	1	-----	53189A
Cover, Capacitor	2	-----	53360A
End Shield, Aluminum	1	-----	40698A
Cover, Wiring	1	-----	40699A
Switch, Start	1	-----	53190A
Centrifugal 4-Pole 60Hz	1	-----	53195A
Label, Connection	1	-----	70787A
Screw, 8-32 x 3/8"	11	-----	85303A
Bearing, Ball - 6203	1	-----	902550
Plate, Mounting	1	-----	53848A
Screw, 10-32 x 1"	6	-----	80141A
Wire Nut, Orange	2	-----	911177
Cord, IEC	1	-----	41053A
Strain Relief	1	-----	747553

**CLARKE® FLOOR
CLEANING MACHINE**

GEARBOX ASSEMBLY

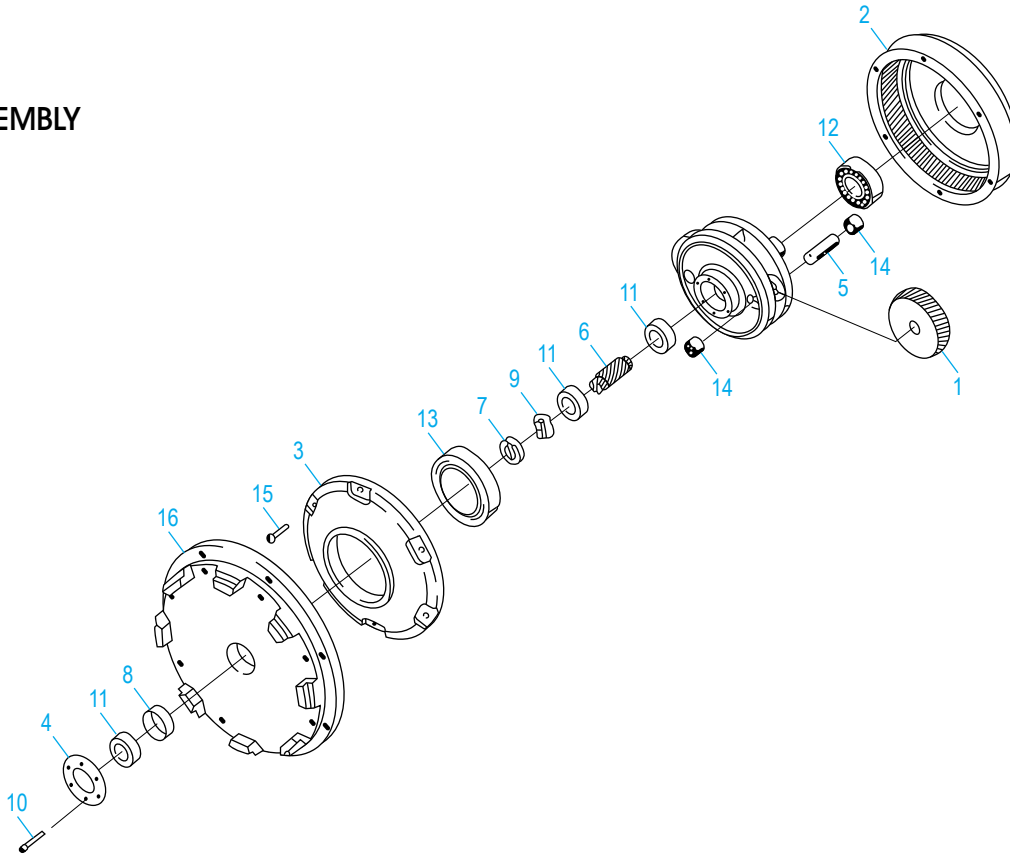

#	DESCRIPTION	QTY.	ULINE PART NO.	MFG. PART NO.
1	Gear, Planet	3	-----	54408A
2	Gear, Ring	1	-----	54856A
3	Cover, Gearbox	1	-----	54858A
4	Retainer, Bearing	1	-----	56922A
5	Shaft, Planet	3	-----	58312A
6	Gear, Pinion	1	-----	58313A
7	Retainer, Shaft	1	-----	58314A
8	Spacer, Sleeve	1	-----	58520A
9	Coupling, Shaft	1	-----	69195A
10	Screw, 10-32 x 1"	6	-----	80141A
11	Bearing, Ball - 6002	3	-----	902606
12	Bearing, Ball - 6204	1	-----	902654
13	Bearing, Ball - 6010	1	-----	902736
14	Bearing, Needle	6	-----	902737
15	Screw, 10-24 x 3/4"	6	-----	84808A
16	Plate, Mounting	1	-----	53848A
	Grease - 14 Ounce Tube (Not Shown)	1	-----	503802

ULINE H-3579, H-4702
**APPAREIL DE NETTOYAGE
 DE PLANCHER CLARK®**

1-800-295-5510
 uline.ca

ENSEMBLE PRINCIPAL

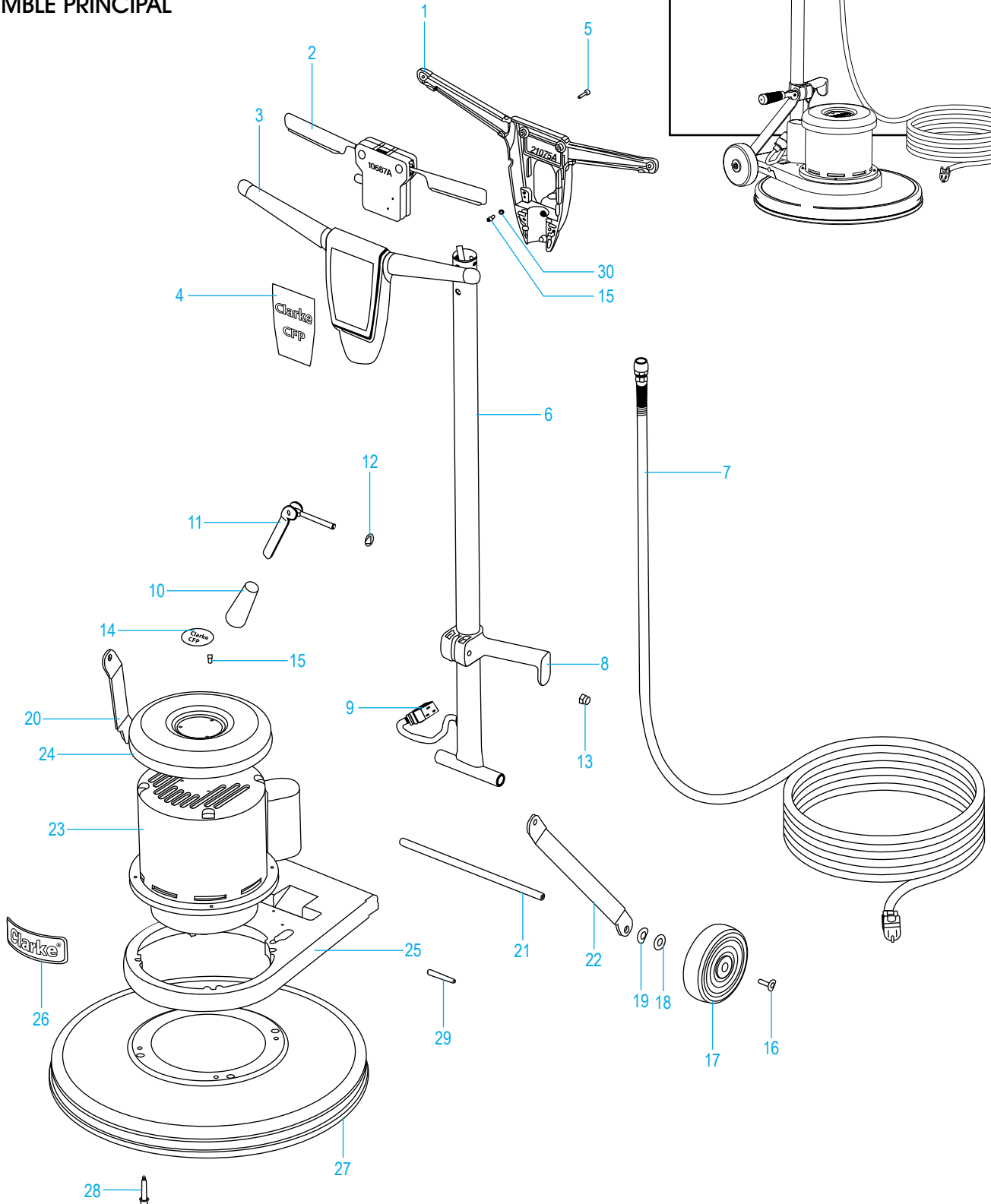
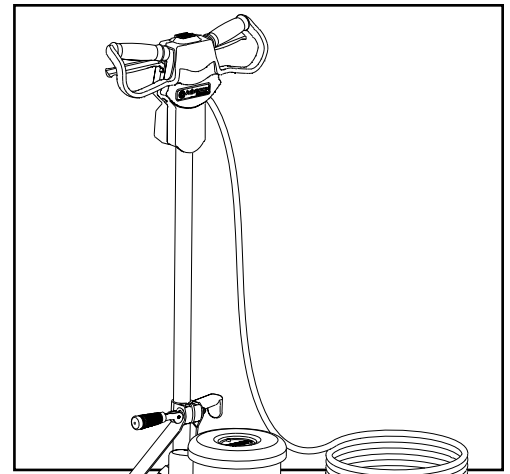

ULINE H-3579, H-4702**APPAREIL DE NETTOYAGE
DE PLANCHER CLARK®**

1-800-295-5510

uline.ca

#	DESCRIPTION	QTÉ.	RÉF. ULINE	RÉF DE FABRICATION
1	Poignée, arrière	1	-----	21075A
2	Module d'interverrouillage	1	-----	10687A
3	Poignée, avant	1	-----	21074A
4	Étiquette de poignée	1	-----	71020A
5	Vis 10-32 x 3/4 po	6	-----	80284A
6	Tube de poignée	1	H-3579-THAND	61373A
7	Cordon d'alimentation 14/3 x 50 pi	1	-----	40788A
	Cordon d'alimentation avec soulagement de traction (non illustré)	1	-----	467504
	Cordon d'alimentation avec cosse femelle à dégagement rapide entièrement isolée (non illustré)	2	-----	47711A
8	Crochet de poignée	1	H-3579-CHAND	50781A
9	Cordon d'interconnexion	1	-----	40789A
10	Prise de poignée	1	-----	56057675
11	Came d'assemblage	1	-----	441401
	Boulon de verrouillage de came (non illustré)	1	-----	441301
	Came de verrouillage (non illustré)	1	-----	461404
	Goupille spiralée (non illustrée)	1	-----	53662A
12	Rondelle d'usure	1	-----	980349
13	Écrou ESNA 16, 3/8 po	1	-----	920342
14	Étiquette (CFP-1700)	1	-----	71023A
14	Étiquette (CFP-2000)	1	-----	71027A
15	Vis 10-32 x 3/8 po	5	-----	80290A
16	Vis 1/4-20 x 1 po	2	-----	80292A
17	Roue	2	-----	56201018
18	Rondelle plate 17/32 x 1 1/16 po	2	-----	980648
19	Rondelle bombée	2	-----	80295A
20	Bras de liaison droit	1	-----	61741A
21	Essieu	1	-----	61725A
22	Bras de liaison gauche	1	-----	61740A
23A	Moteur (Voir page 7)	1	H-3581	40763A
23B	Boîte à engrenages (Voir page 8)	1	-----	53646A
24	Couvercle ramasse-gouttes	1	-----	61716A
25	Bâti principal	1	-----	21088A
26	Étiquette Clarke du moteur	1	-----	73323A
27	Ensemble de boîtier (CFP-1700)	1	-----	11006A
	Boîtier (CFP-1700)	1	-----	61715A
	Butoir (CFP-1700)	1	-----	30381A
27	Ensemble de boîtier (CFP-2000)	1	-----	11007A
	Boîtier (CFP-2000)	1	-----	61714A
	Butoir (CFP-2000)	1	-----	50784A
28	Vis 5/16 po - 18	4	-----	80294A
29	Goupille fendue 1/2 po	2	-----	53833A
30	Rondelle plate n° 10	1	-----	80291A
	Plateau d'entraînement de tampon (CFP-1700) (non illustré)	1	-----	30638A
	Plateau d'entraînement de tampon (CFP-2000) (non illustré)	1	-----	30639A

ULINE H-3579, H-4702
**APPAREIL DE NETTOYAGE
 DE PLANCHER CLARK®**

1-800-295-5510
 uline.ca

ENSEMBLE MOTEUR

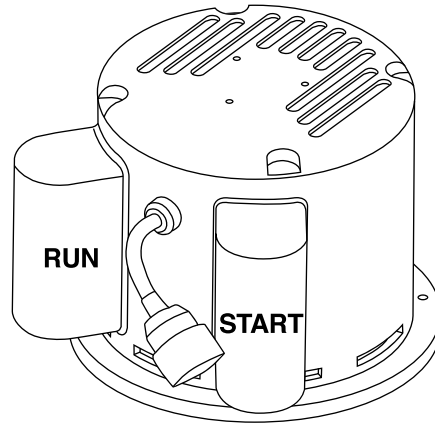

DESCRIPTION	QTÉ.	RÉF. ULINE	RÉF DE FABRICATION
Rotor, 1,5 HP, 60 Hz	1	-----	53193A
Condensateur de démarrage	1	-----	40694A
Condensateur de marche	1	-----	53191A
Stator, 1,5 HP, 60 Hz	1	-----	53189A
Couvercle de condensateur	2	-----	53360A
Bouclier d'extrémité en aluminium	1	-----	40698A
Couvercle de câblage	1	-----	40699A
Interrupteur de démarrage	1	-----	53190A
Centrifuge quadripolaire 60 Hz	1	-----	53195A
Étiquette de branchement	1	-----	70787A
Vis 8-32 x 3/8 po	11	-----	85303A
Roulement à billes 6203	1	-----	902550
Plateau de montage	1	-----	53848A
Vis 10-32 x 1 po	6	-----	80141A
Connecteur de fils orange	2	-----	911177
Cordon d'alimentation homologué CEI	1	-----	41053A
Serre-câble	1	-----	747553

ULINE H-3579, H-4702
**APPAREIL DE NETTOYAGE
 DE PLANCHER CLARK®**

1-800-295-5510
 uline.ca

ENSEMBLE BOÎTE À ENGRENAGES

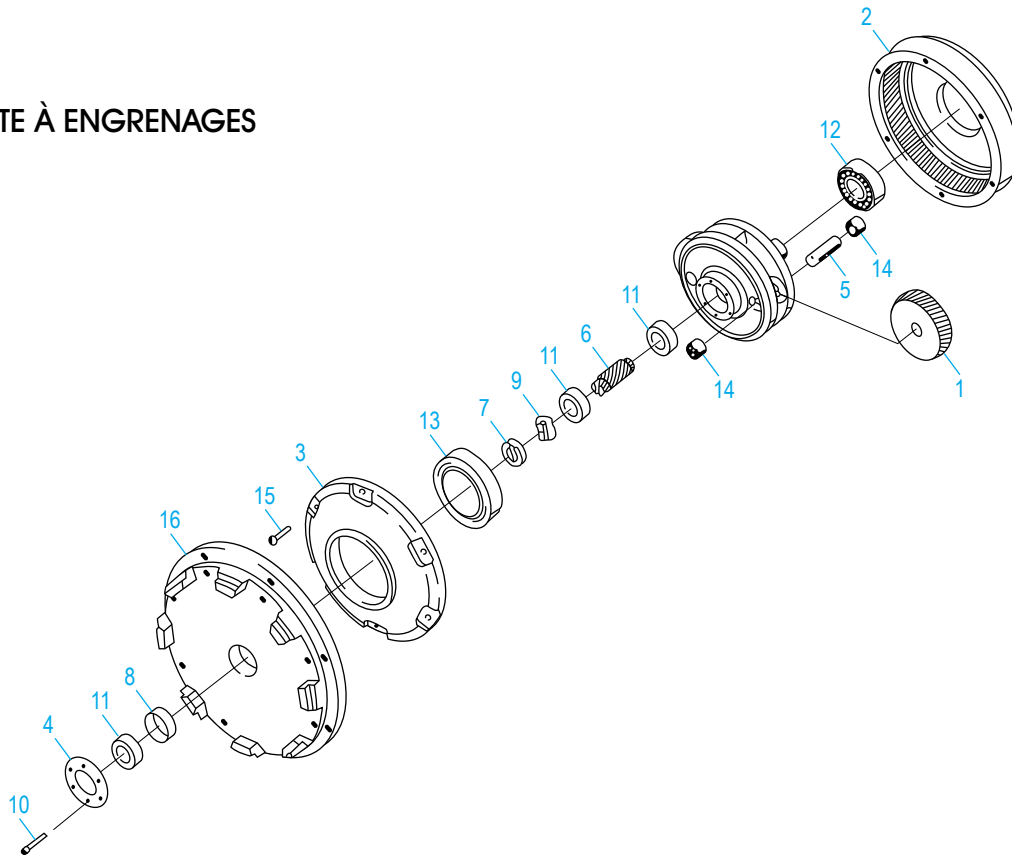

#	DESCRIPTION	QTÉ.	RÉF. ULINE	RÉF DE FABRICATION
1	Engrenage planétaire	3	-----	54408A
2	Couronne planétaire	1	-----	54856A
3	Couvercle de boîte à engrenages	1	-----	54858A
4	Plaque de retenue de roulement	1	-----	56922A
5	Arbre d'engrenage planétaire	3	-----	58312A
6	Pignon	1	-----	58313A
7	Dispositif de retenue d'arbre	1	-----	58314A
8	Douille-entretoise	1	-----	58520A
9	Coupleur d'arbres	1	-----	69195A
10	Vis 10-32 x 1 po	6	-----	80141A
11	Roulement à billes 6002	3	-----	902606
12	Roulement à billes 6204	1	-----	902654
13	Roulement à billes 6010	1	-----	902736
14	Roulement à aiguilles	6	-----	902737
15	Vis 10-24 x 3/4 po	6	-----	84808A
16	Plateau de montage	1	-----	53848A
	Graisse, tube de 414 ml (14 oz) (non illustré)	1	-----	503802